

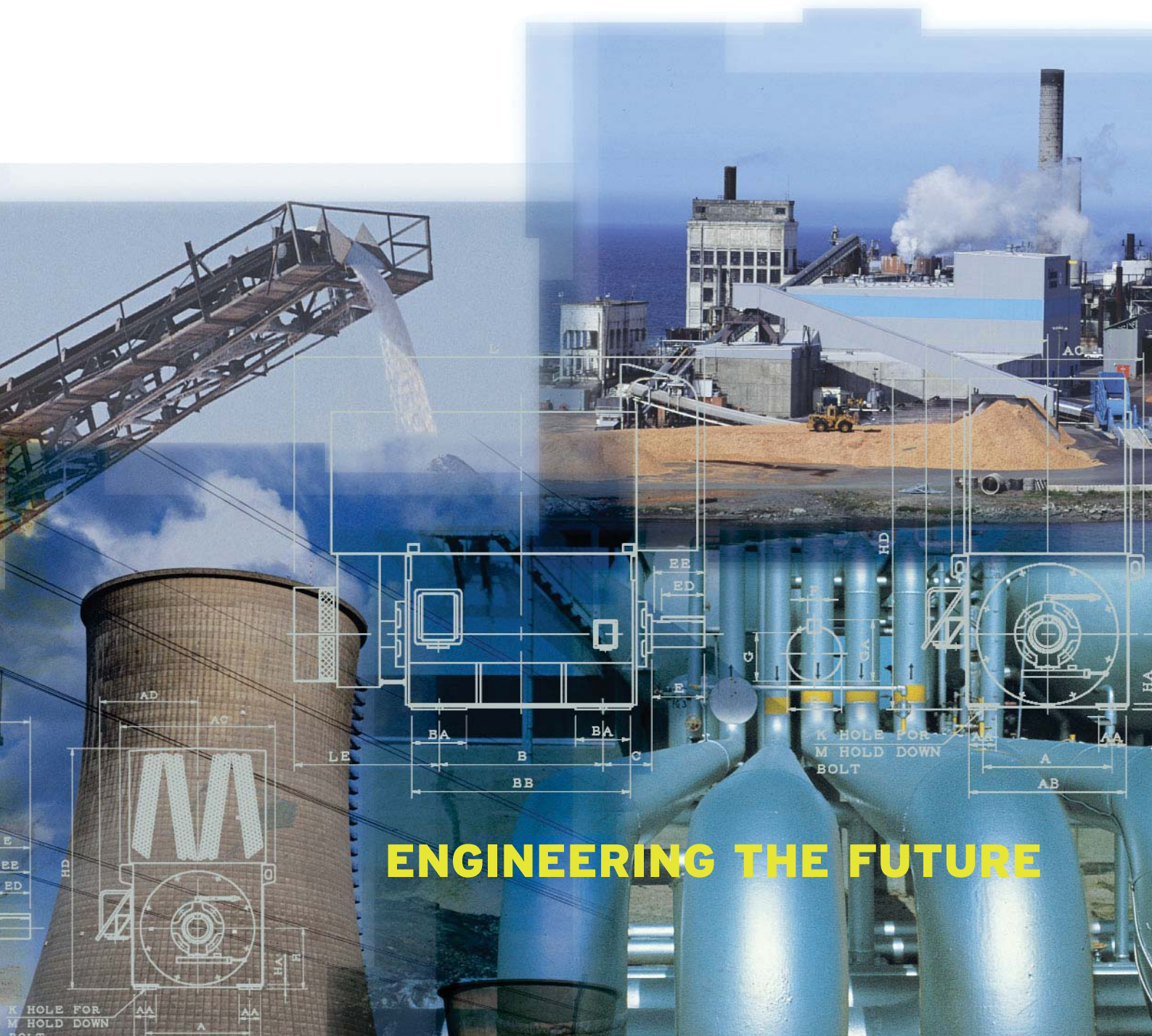

Large and High Voltage Motors

Bespoke construction to your needs



ENGINEERING THE FUTURE



2

TECO MOTOR PRODUCTS

- Low voltage induction motors - IEC and NEMA
- High voltage induction motors
- Inverters
- Eddy current variable speed drives
- Drip proof motors - LV and HV
- DC motors
- Synchronous motors
- Vertical hollow shaft motors
- Hazardous area motors
- High efficiency motors
- Brake motors
- Stepper motors
- Switchgear

TECO PUBLICATIONS AVAILABLE

- Product overview
- Advantage IEC/Advantage+ high and premium efficiency cast iron motors
- Advantage Lite Aluminium motors
- Advantage Lite Brake motors
- Open Advantage drip proof motors
- Low voltage
- High voltage motors
- Large and High Voltage motors
- Slip ring motors
- Advantage Guardian range - high temperature resistant motors
- Minicon palm drive
- Minicon+ IP65 drive
- Speecon 7200JA variable speed drives
- Speecon 7200MA variable speed drives
- Speecon 7200GA variable speed drives
- Optim 2000 variable speed drives

Large and

LARGE AND HIGH VOLTAGE MOTOR RANGE FROM TECO

TECO's position as a world leader in the design and manufacturing of large induction motors is secured by an unflinching commitment to engineering excellence and technological innovation. For a half a century TECO motors have been recognized as industry leaders in dependability and quality.

AVAILABLE IN BOTH IEC AND NEMA FRAMES AND SPECIFICATIONS

Voltage Options:

- Low voltage to 750kW (<690V)
- 3.3kV from 75kW
- 6.6kV from 110kW
- 11kV from 250kW
- 13.2kV from 500kW

Mounting Options:

- Vertical or Horizontal
- Foot and/or flange configurations

Enclosures:

- TEFC = Totally Enclosed Fan Cooled (IC411)
- TECACA = Totally Enclosed, Closed Air Circuit, Air Cooled (IC611)
- TECACW = Totally Enclosed, Closed Air Circuit, Water Cooled (IC81W)
- ODP = Open Dripproof (IC01)
- WPI = NEMA 1 Weatherprotected (IC01)
- WP11 = NEMA 2 Weatherprotected (IC01)



High Voltage Motors

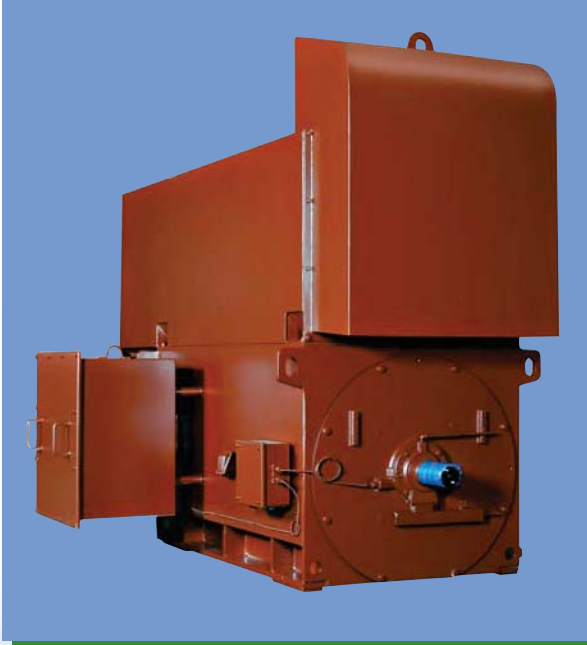

EXPERIENCE



APPLICATION

Crown Series motors are custom designed to each customer's specific application. Because of their design versatility and high operating efficiencies, Crown Series motors are the logical choice for a multitude of industries including oil and gas, petro-chemical, pulp and paper, electric utility, water and waste water, marine, steel, mining and air separation.

Typical application of Crown Series motors include agitators, blowers, boring mills, pumps, conveyors, crushers, fans, and many more.

Tilcon Quarry, Skipton, UK

In 1999 TECO-Westinghouse was awarded the contract to supply, test and commission motors and drives to operate crushers at the UK's most advanced quarry.

The Tilcon Quarry produces up to two million tonnes of limestone a year. We supplied them with two induction motors, including the largest AC variable speed motor in the UK (1000kW 6 pole 690V, TECACA).

TECO-Westinghouse also supplied two 12 pulse cubicalised inverters, rated at 450kW and 1000kW and a 2000kVA ONAN 11kV to 690V stepdown/phase shift transformer.

TECO GROUPS

TECO Groups have project capability experiences in the following industry sectors, power generation, petro-chemical, mining, paper and quarrying.

With our widest ever product range TECO Groups can provide you with motors and drives to cover virtually every project.

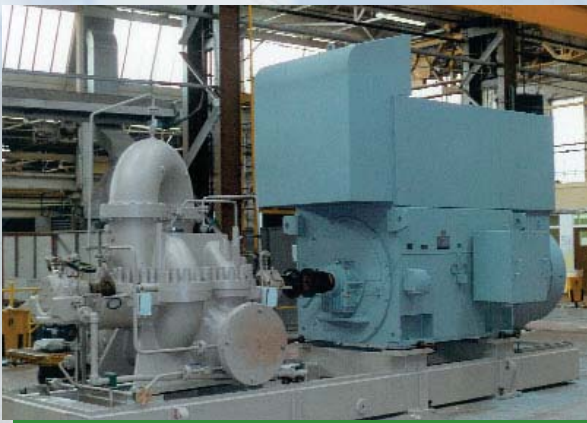

Construction

WINDING/INSULATION - FORM WOUND V.P.I. CLASS 'F' SYSTEM

The insulation system determines the 'life' of a motor. Motor capacity is influenced by the quality of insulation.

TECO utilises mica tape as its base material, which is impregnated with a special epoxy resin. Impregnation is accomplished by immersion of the completely assembled stator in the special resin using a vacuum pressure cycle. This ensures outstanding resistance to heat, moisture, and chemicals, and guarantees safe operation even under most severe environmental conditions

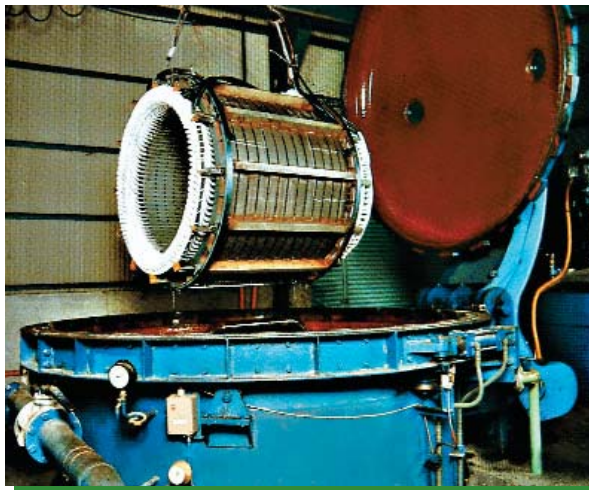

STATOR FRAME CONSTRUCTION

Crown Series motors use box frame construction to provide frames that have the mechanical strength and stability to assure years of dependable, economical

performance. The fabricated steel frames are braced by heavy steel plate bulkheads and end plates to make the frames both laterally and torsionally stable. End brackets are reinforced to give the bearings rigid support and to minimize bearing stiffness.



STATOR WINDING BRACING

Bracing rings of insulated steel or epoxy glass yarn are used. Individual coils are lashed to the ring with glass cord. Impregnated felt packers are used between coil sides.

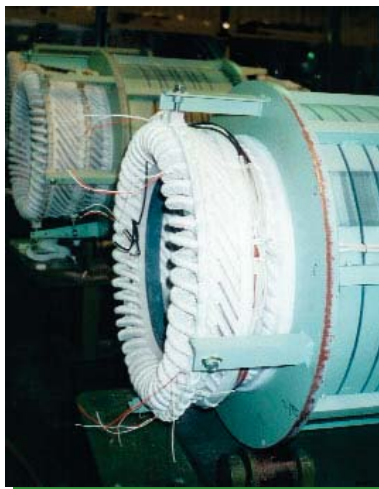

Support of the coil ends is designed to restrain shock and vibration of the coil ends under heavy overload conditions such as those which occur during full voltage starting.

ROTOR CONSTRUCTION

TECO induction motor rotors are recognised as the most reliable in the industry, and their high performance standards are a hallmark of the Crown Series motors. Standard construction utilises copper-copper/alloy bars, a time-proven choice for rotor construction because it provides maximum performance and reliability, and high quality silicon steel laminations to minimise losses resulting in high efficiency values.

Connection between rotor bars and end rings are joined together using silver brazing and a "1 shot" brazing technique developed by TECO.

Rotors balanced to 'N' grade as per BSEN and Nema standards.





Bearings

ADVANCED BEARING SYSTEM FOR RELIABLE PERFORMANCE

The bearing system used in Crown Series Motors has been designed and engineered for continuous, reliable performance and ease of maintenance. Both anti-friction and split-sleeve bearings are offered. Bearing insulation can also be added when required.

ANTI-FRICTION BEARINGS

Grease lubricated roller bearings are mounted directly into the bores of the endshields. High quality vacuum degassed roller bearings are used for long life and quiet operation.

SPLIT-SLEEVE BEARINGS

Our split-sleeve bearings are spherically seated and self-aligning, thus providing ease of maintenance in all field conditions. Shaft mounted oil rings transfer the oil from the reservoir to the bearing with gravity feeding back into the reservoir. This bearing system employs a sophisticated sealing system that is designed to eliminate oil leakage along the shaft. The oil ring lubrication process can be easily modified for flood lubrication.

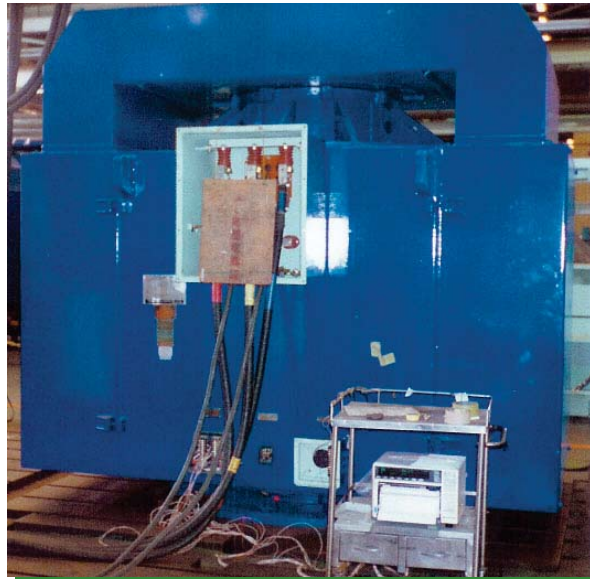

5

Testing

100% ROUTINE TEST

Quality is emphasised at each step as a motor proceeds through each stage of design, assembly and testing.

Each motor is given a routine test as required by JEC2137, IEC34, BS4999, AS1359 or NEMA MG 1 IEEE-112 to determine that it is free from electrical or mechanical defects.

Additional special tests beyond the routine test are available on request. Tests may be witnessed if required.

TOTALLY ENCLOSED AIR-TO-AIR COOLED TYPE. SQUIRREL CAGE ROTOR.

Figure 1.

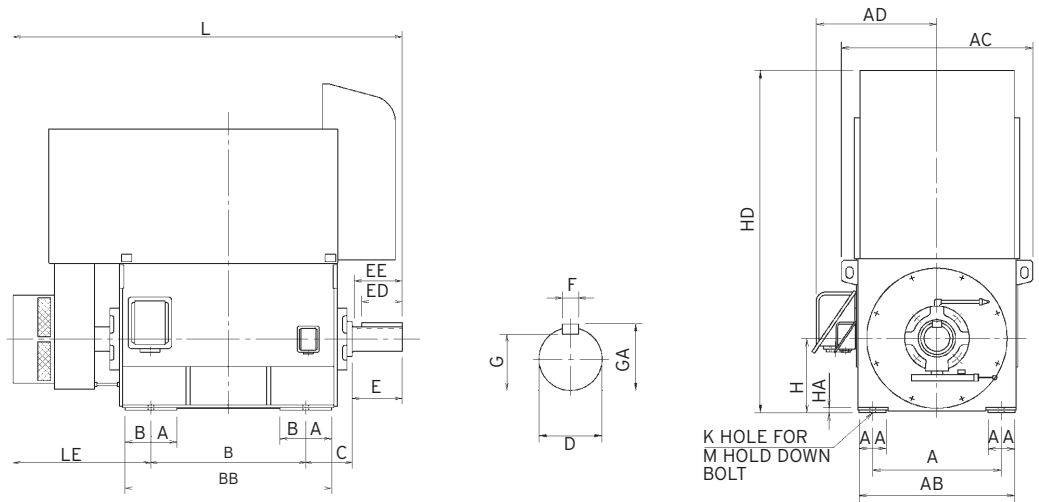

Frame No.	No. of Poles	Fig.	Mounting									AC	AD	H	HA	HD	L	LE	Shaft Extension				Key Size			Frame No.
			A	AA	AB	B	BA	BB	C	K	M								D	E	EE	G	ED	F	GA	
400A	2P	1	800	85	894	800	240	1149	280	35	M24	1120	789	400	36	1996	2173	953	70	140	127	62.5	110	20	74.5	400A
400C	2P	1	800	85	894	1000	240	1349	280	35	M24	1120	789	400	36	1996	2373	953	70	140	127	62.5	110	20	74.5	400C
400C	4P & UP	2	800	85	894	1000	240	1349	280	35	M24	1120	785	400	36	1658	2254	764	110	210	197	100	160	28	116	400C
450A	2P	1	900	85	994	900	280	1318	315	35	M24	1220	839	450	37	2198	2345	990	70	140	127	62.5	110	20	74.5	450A
450A	4P & UP	2	900	85	994	900	280	1324	315	35	M24	1220	835	450	37	1811	2226	801	110	210	197	100	160	28	116	450A
450C	4P	1	900	85	994	1120	280	1544	315	35	M24	1220	835	450	37	2198	2705	1060	110	210	197	100	160	28	116	450C
450C	6P & UP	2	900	85	994	1120	280	1544	315	35	M24	1220	835	450	37	1811	2446	801	110	210	197	100	160	28	116	450C
500A	4P	1	1000	100	1114	1000	280	1418	335	42	M30	1360	895	500	37	2418	2770	1225	125	210	197	114	160	32	132	500A
500A	6P & UP	2	1000	100	1114	1000	280	1418	335	42	M30	1360	895	500	37	1973	2416	871	125	210	197	114	160	32	132	500A
500C	4P	1	1000	100	1114	1250	280	1668	335	42	M30	1360	895	500	37	2418	3020	1225	125	210	197	114	160	32	132	500C
500C	6P & UP	2	1000	100	1114	1250	280	1668	335	42	M30	1360	895	500	37	1973	2666	871	125	210	197	114	160	32	132	500C
560A	4P, 6P	1	1180	100	1244	1120	280	1538	355	42	M30	1490	960	560	51	2764	3030	1305	140	250	237	128	200	36	148	560A
560A	8P & UP	2	1180	100	1244	1120	280	1538	355	42	M30	1490	960	560	51	2211	2646	921	140	250	237	128	200	36	148	560A
560C	6P	1	1180	100	1244	1400	280	1818	355	42	M30	1490	960	560	51	2764	3310	1305	140	250	237	128	200	36	148	560C
560C	8P & UP	2	1180	100	1244	1400	280	1818	355	42	M30	1490	960	560	51	2211	2926	921	140	250	237	128	200	36	148	560C
630A	6P	1	1250	132	1406	1250	355	1714	375	48	M36	1660	1046	630	58	2995	3255	1330	160	300	287	147	250	40	169	630A
630A	8P & UP	2	1250	132	1406	1250	355	1714	375	48	M36	1660	1046	630	58	2416	2871	946	160	300	287	147	250	40	169	630A
630C	6P	1	1250	132	1406	1600	355	2064	375	48	M36	1660	1046	630	58	2995	3605	1330	160	300	287	147	250	40	169	630C
630C	8P & UP	2	1250	132	1406	1600	355	2064	375	48	M36	1660	1046	630	58	2416	3221	946	160	300	287	147	250	40	169	630C
710A	6P	1	1400	180	1488	1400	380	1914	400	48	M36	1782	1087	710	58	3254	3455	1355	160	300	287	147	250	40	169	710A
710A	8P & UP	2	1400	180	1488	1400	380	1914	400	48	M36	1782	1087	710	58	2623	3071	971	160	300	287	147	250	40	169	710A
710B	6P	1	1400	180	1488	1600	380	2114	400	48	M36	1782	1087	710	58	3254	3655	1355	160	300	287	147	250	40	169	710B
710B	8P & UP	2	1400	180	1488	1600	380	2114	400	48	M36	1782	1087	710	58	2623	3271	971	160	300	287	147	250	40	169	710B
710C	8P & UP	2	1400	180	1488	1800	380	2314	400	48	M36	1782	1087	710	58	2623	3855	1355	160	300	287	147	250	40	169	710C
800A	8P & UP	2	1700	180	1790	1600	380	2114	425	55	M42	2084	1238	800	58	3078	3400	1075	180	300	287	165	250	45	190	800A
800B	8P & UP	2	1700	180	1790	1800	380	2314	425	55	M42	2084	1238	800	58	3078	3600	1075	180	300	287	165	250	45	190	800A

Dimensions in mm

Figure 2.

NOTES

1. Tolerance of shaft extension diameter $D = m6$
2. Tolerance of shaft centre height $H = \begin{matrix} 0 \\ + \end{matrix}$ for F#630 & below $\begin{matrix} 0 \\ - \end{matrix}$ for F#710 & up
3. Tolerance of key width $F = h9$
4. Usable Shaft Length: EE
5. Anti-friction bearings

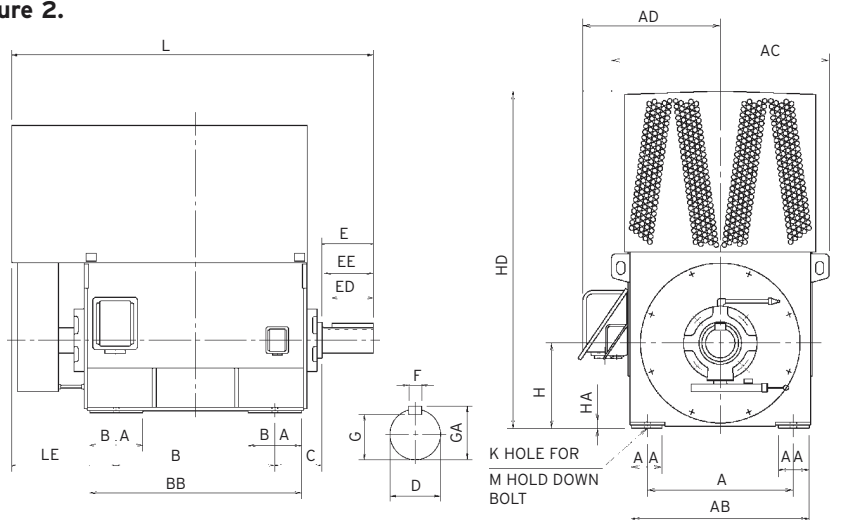

TOTALLY ENCLOSED AIR-TO-AIR COOLED TYPE. SQUIRREL CAGE ROTOR.

Figure 3.

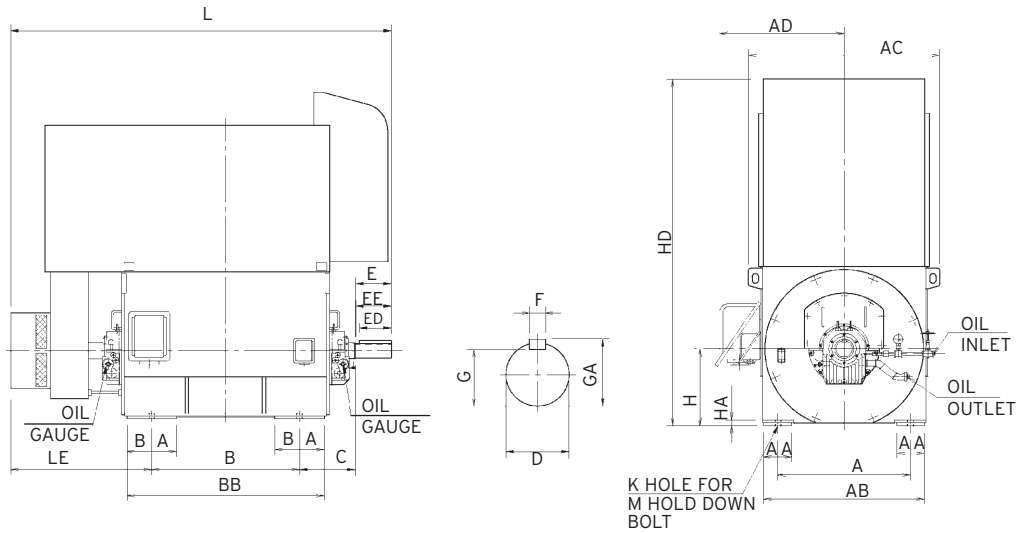

Frame No.	No. of Poles	Fig.	Mounting									AC	AD	H	HA	HD	L	LE	Shaft Extension				Key Size			Frame No.
			A	AA	AB	B	BA	BB	C	K	M								D	E	EE	G	ED	F	GA	
400D	2P	3	800	85	894	1120	240	1469	375	35	M24	1120	796	400	36	1996	2698	1033	85	170	164	76	140	22	90	400D
450B	2P	3	900	85	994	1000	280	1418	425	35	M24	1220	839	450	37	2198	2665	1070	85	170	164	76	140	22	90	450B
450D	2P	3	900	85	994	1250	280	1668	425	35	M24	1220	839	450	37	2198	3015	1170	85	170	164	76	140	22	90	450D
500B	2P	3	1000	100	1114	1120	370	1532	450	42	M30	1360	899	500	37	2418	3120	1380	85	170	164	76	140	22	90	500B
500D	2P	3	1000	100	1114	1400	370	1812	450	42	M30	1360	899	500	37	2418	3400	1380	95	170	164	86	140	25	100	500D
560C	4P	3	1180	100	1244	1400	280	1818	450	42	M30	1490	960	560	51	2764	3500	1400	140	250	244	128	200	36	148	560C
560D	2P	3	1180	100	1244	1600	405	2006	450	42	M30	1490	964	560	51	2764	3580	1320	110	210	204	100	160	28	116	560D
560D	2P	3	1180	100	1244	1600	405	2006	450	42	M30	1490	964	560	51	2764	3680	1420	110	210	204	100	160	28	116	560D
630A	4P	3	1250	132	1406	1250	355	1714	500	48	M36	1660	1046	630	58	2995	3425	1425	140	250	244	128	200	36	148	630A
630C	4P	3	1250	132	1406	1600	355	2064	500	48	M36	1660	1046	630	58	2995	3825	1425	160	300	294	147	250	40	169	630C
710A	4P	3	1400	180	1488	1400	380	1914	560	48	M36	1782	1087	710	58	3254	3710	1450	180	300	287	165	250	45	190	710A
710B	4P	3	1400	180	1488	1600	380	2114	560	48	M36	1782	1087	710	58	3254	3910	1450	180	300	287	165	250	45	190	710B
800A	6P	3	1700	180	1790	1600	380	2114	560	55	M42	2084	1238	800	58	3702	4000	1540	180	300	287	165	250	45	190	800A
800B	6P	3	1700	180	1790	1800	380	2314	560	55	M42	2084	1238	800	58	3702	4200	1540	180	300	287	165	250	45	190	800B
900A	6P	3	1800	220	1995	1800	430	2310	600	55	M42	2301	1338	900	65	3950	4400	1650	200	350	337	185	280	45	210	900A
900A	8P & UP	4	1800	220	1995	1800	430	2310	600	55	M42	2301	1338	900	65	3293	3865	1115	200	350	337	185	280	45	210	900A

7

Dimensions in mm

Figure 4.

NOTES

1. Tolerance of shaft extension diameter $D = m6$
2. Tolerance of shaft centre height $H = \begin{smallmatrix} \varnothing \\ \varnothing \end{smallmatrix}$ for F#630 & below $\begin{smallmatrix} \varnothing \\ -0.18 \end{smallmatrix}$ for F#710 & up
3. Tolerance of key width $F = h9$
4. Usable Shaft Length: EE
5. Sleeve bearings
6. Provision for noncontactive vibration probe, distance of "C" has to be changed:
F#400-450:C+70, F#500-560: C+80
7. F#500B & Below, self lubrication bearing. All others must be force lubrication.

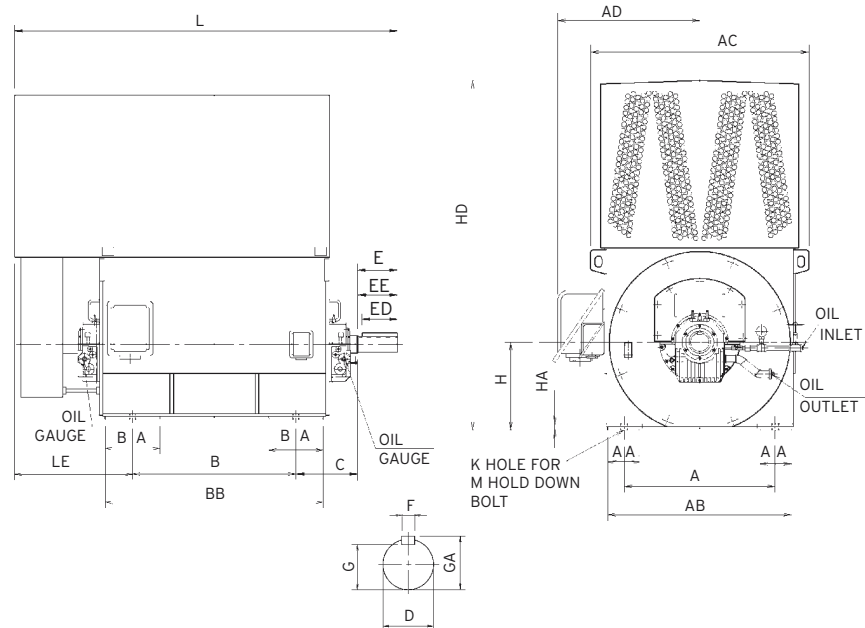

NEMA WEATHER PROTECTED TYPE I/OPEN DRIP-PROOF TYPE, SQUIRREL CAGE ROTOR.

Figure 5.

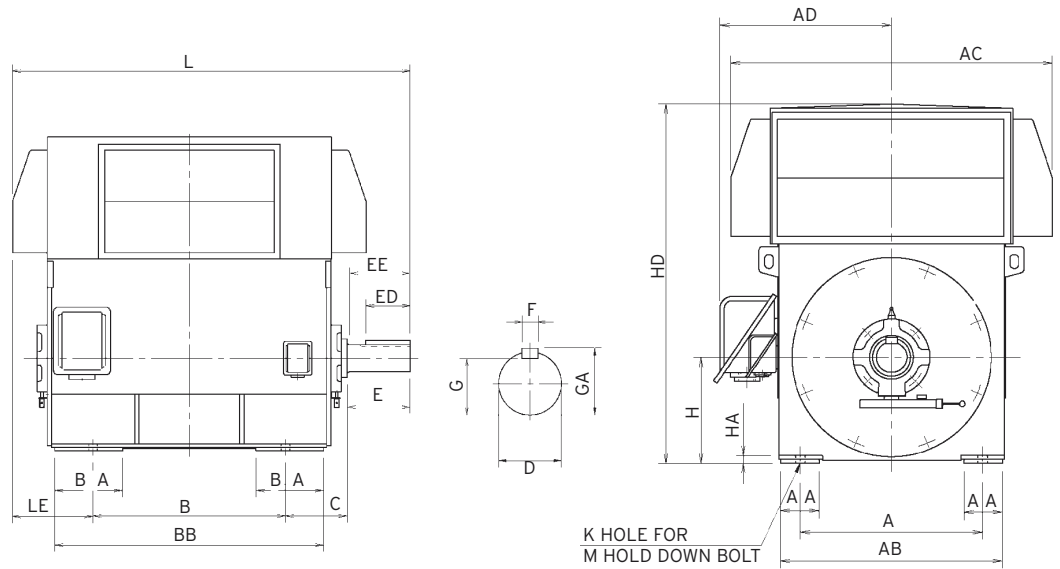

Frame No.	No. of Poles	Fig.	Mounting									AC	AD	H	HA	HD	L	LE	Shaft Extension				Key Size			Frame No.
			A	AA	AB	B	BA	BB	C	K	M								D	E	EE	G	ED	F	GA	
355A	2P	5	710	85	794	710	230	1034	254	28	M20	1237	736	355	35	1247	1490	386	70	140	132	62.5	110	20	74.5	355A
355C	2P	5	710	85	794	900	230	1224	254	28	M20	1237	736	355	35	1247	1680	386	70	140	132	62.5	110	20	74.5	355C
355C	4P & UP	5	710	85	794	900	230	1224	254	28	M20	1237	736	355	35	1247	1710	386	95	170	162	86	140	25	100	355C
400A	4P & UP	5	800	85	894	800	240	1149	280	35	M24	1337	785	400	36	1347	1689	399	110	210	200	100	160	28	116	400A
400C	2P	5	800	85	894	1000	240	1349	280	35	M24	1337	785	400	36	1347	1819	399	70	140	132	62.5	110	20	74.5	400C
400C	4P & UP	5	800	85	894	1000	240	1349	280	35	M24	1337	785	400	36	1347	1889	399	110	210	200	100	160	28	116	400C
450A	4P & UP	5	900	85	994	900	280	1324	315	35	M24	1537	835	450	37	1449	1861	436	125	210	202	114	160	32	132	450A
450C	4P & UP	5	900	85	994	1120	280	1544	315	35	M24	1537	835	450	37	1449	2081	436	125	210	202	114	160	32	132	450C
500A	4P & UP	5	1000	100	1114	1000	280	1418	335	42	M30	1757	895	500	37	1664	2071	486	140	250	240	128	200	36	148	500A
500C	6P & UP	5	1000	100	1114	1250	280	1668	335	42	M30	1757	895	500	37	1664	2321	486	140	250	240	128	200	36	148	500C
560A	6P & UP	5	1180	100	1244	1120	280	1538	355	42	M30	1887	960	560	51	1838	2261	486	160	300	290	147	250	40	169	560A
560C	6P & UP	5	1180	100	1244	1400	280	1818	355	42	M30	1887	960	560	51	1838	2541	486	160	300	290	147	250	40	169	560C
630A	6P & UP	5	1250	132	1406	1250	355	1714	375	48	M36	2157	1046	630	58	2022	2486	561	160	300	290	147	250	40	169	630A
630C	6P & UP	5	1250	132	1406	1600	355	2064	375	48	M36	2157	1046	630	58	2022	2836	561	160	300	290	147	250	40	169	630C
710A	6P & UP	5	1400	180	1488	1400	380	1914	400	48	M36	2237	1087	710	58	2237	2686	586	160	300	290	147	250	40	169	710A

Dimensions in mm

NOTES

1. Tolerance of shaft extension diameter $D = m6$
2. Tolerance of shaft centre height $H = \begin{matrix} 0 \\ -0.05 \end{matrix}$ for F#630 & below $\begin{matrix} 0 \\ -0.08 \end{matrix}$ for F#710 & up
3. Tolerance of key width $F = h9$
4. Usable Shaft Length: EE
5. Anti-friction bearings



NEMA WEATHER PROTECTED TYPE I/OPEN DRIP-PROOF TYPE, SQUIRREL CAGE ROTOR.

Figure 6.

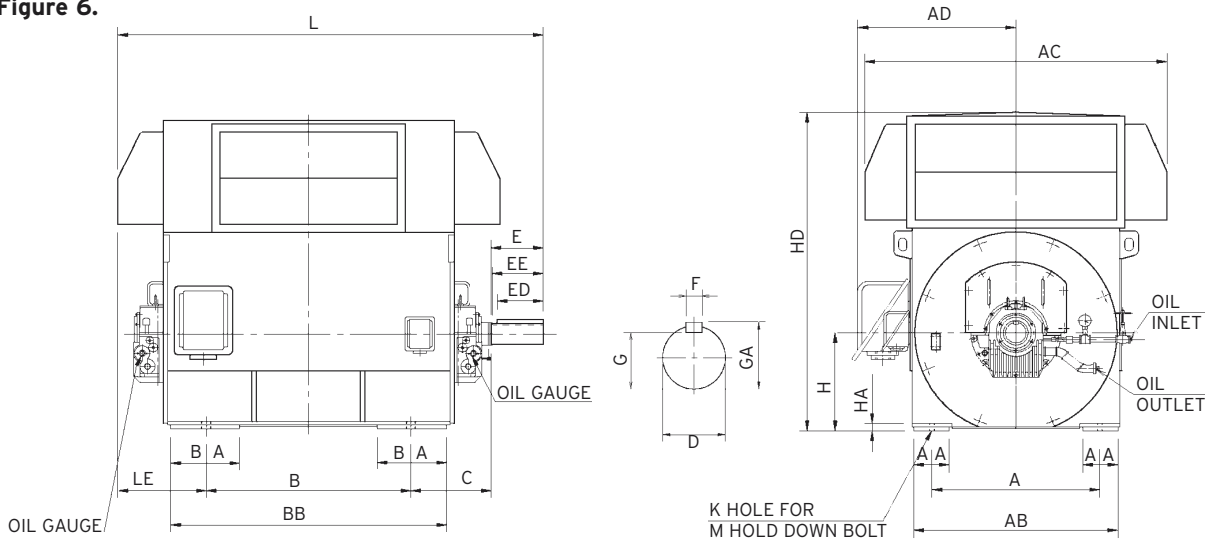

Frame No.	No. of Poles	Fig.	Mounting									AC	AD	H	HA	HD	L	LE	Shaft Extension				Key Size			Frame No.
			A	AA	AB	B	BA	BB	C	K	M								D	E	EE	G	ED	F	GA	
400D	2P	6	800	85	894	1120	240	1469	375	35	M24	1337	786	400	36	1347	2064	399	85	170	164	76	140	22	90	400D
450B	2P	6	900	85	994	1000	280	1418	425	35	M24	1537	836	450	37	1449	2031	436	85	170	164	76	140	22	90	450B
450D	2P	6	900	85	994	1250	280	1668	425	35	M24	1537	836	450	37	1449	2281	436	95	170	164	86	140	25	100	450D
500B	2P	6	1000	100	1114	1120	370	1532	450	42	M30	1757	896	500	37	1664	2226	486	95	170	164	86	140	25	100	500B
500C	4P	6	1000	100	1114	1250	280	1668	450	42	M30	1757	896	500	37	1664	2436	486	140	250	244	128	200	36	148	500C
500D	2P	6	1000	100	1114	1400	370	1812	450	42	M30	1757	896	500	37	1664	2546	486	110	210	204	100	160	28	116	500D
560A	4P	6	1180	100	1244	1120	280	1538	450	42	M30	1887	960	560	51	1838	2306	486	140	250	244	128	200	36	148	560A
560C	4P	6	1180	100	1244	1400	280	1818	450	42	M30	1887	960	560	51	1838	2586	486	140	250	244	128	200	36	148	560C
560D	6P & UP	6	1180	100	1244	1600	280	2006	450	42	M30	1887	960	560	51	1838	2636	486	160	300	294	147	250	40	169	560D
630A	2P	6	1180	100	1244	1600	405	2006	450	42	M30	1887	960	560	51	1838	2746	486	125	210	204	114	160	32	132	630D
630A	4P & UP	6	1250	132	1406	1250	355	1714	500	48	M36	2157	1046	630	58	2022	2611	561	160	300	294	147	250	40	169	630A
630C	2P	6	1250	132	1406	1600	355	2064	500	48	M36	2157	1046	630	58	2022	2871	561	125	210	204	114	160	32	132	630C
630C	4P	6	1250	132	1406	1600	355	2064	500	48	M36	2157	1046	630	58	2022	2961	561	160	300	294	147	250	40	169	630C
630C	6P & UP	6	1250	132	1406	1600	355	2064	500	48	M36	2157	1046	630	58	2022	3061	561	180	300	287	165	250	45	190	630C
710A	4P	6	1400	180	1488	1400	380	1914	560	48	M36	2237	1087	710	58	2237	2846	586	160	300	294	147	250	40	169	710A
710A	6P & UP	6	1400	180	1488	1400	380	1914	560	48	M36	2237	1087	710	58	2237	2946	586	180	300	287	165	250	45	190	710A
710B	4P	6	1400	180	1488	1600	380	2114	560	48	M36	2237	1087	710	58	2237	3046	586	160	300	294	147	250	40	169	710B
710B	6P & UP	6	1400	180	1488	1600	380	2114	560	48	M36	2237	1087	710	58	2237	3146	586	180	300	287	165	250	45	190	710B
710C	4P	6	1400	180	1488	1800	380	2314	560	48	M36	2237	1087	710	58	2237	3246	586	160	300	294	147	250	40	169	710C
710C	6P & UP	6	1400	180	1488	1800	380	2314	560	48	M36	2237	1087	710	58	2237	3346	586	180	300	287	165	250	45	190	710C
800A	4P	6	1700	180	1790	1600	380	2114	560	55	M42	2642	1238	800	58	2592	3096	636	180	300	287	165	250	45	190	800A
800A	6P & UP	6	1700	180	1790	1600	380	2114	560	55	M42	2642	1238	800	58	2592	3196	636	200	350	337	185	280	45	210	800A
800B	4P	6	1700	180	1790	1800	380	2314	560	55	M42	2642	1238	800	58	2592	3296	636	180	300	287	165	250	45	190	800B
800B	6P & UP	6	1700	180	1790	1800	380	2314	560	55	M42	2642	1238	800	58	2592	3346	636	200	350	337	185	280	45	210	800B
900A	6P & UP	6	1800	220	1995	1800	430	2310	600	55	M42	2847	1338	900	65	2900	3386	636	220	350	337	203	280	50	231	900A

Dimensions in mm

NOTES

1. Tolerance of shaft extension diameter D = m6
2. Tolerance of shaft centre height H = $\begin{smallmatrix} 0 \\ -0.15 \end{smallmatrix}$ for F#630 & below $\begin{smallmatrix} 0 \\ -0.18 \end{smallmatrix}$ for F#710 & up
3. Tolerance of key width F = h9
4. Usable Shaft Length: EE
5. Sleeve bearings
6. Provision for noncontactive vibration probe, distance of "C" has to be changed: F#400-450:C+70, F#500-560: C+80
7. F#500B & Below, self lubrication bearing. All others must be force lubrication.

NEMA WEATHER PROTECTED TYPE II. SQUIRREL CAGE ROTOR.

Figure 7.

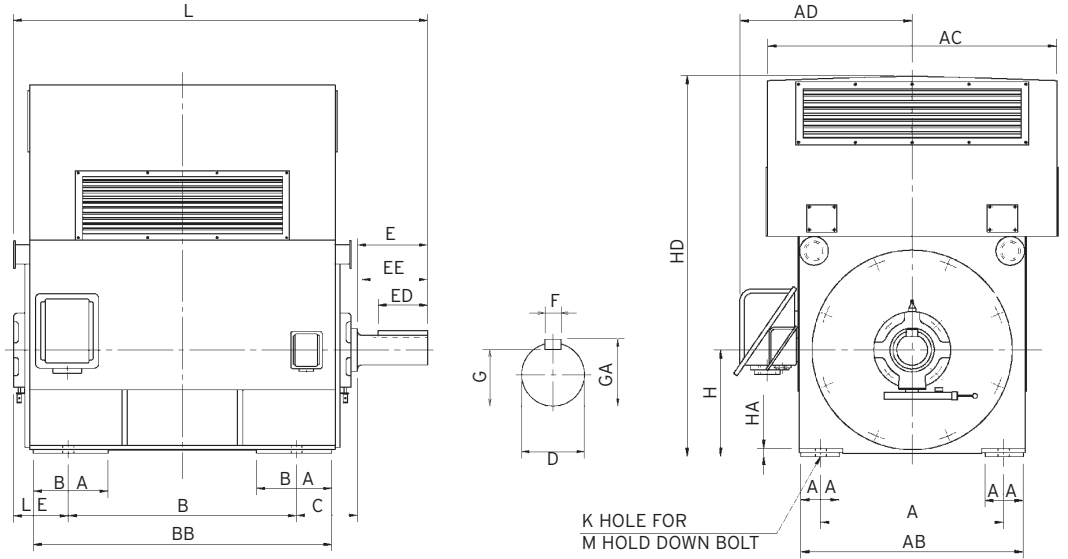

Frame No.	No. of Poles	Fig.	Mounting									AC	AD	H	HA	HD	L	LE	Shaft Extension				Key Size			Frame No.
			A	AA	AB	B	BA	BB	C	K	M								D	E	EE	G	ED	F	GA	
355A	2P	7	710	85	794	710	230	1034	254	28	M20	1092	736	355	35	1535	1358	254	70	140	132	62.5	110	20	74.5	355A
355C	2P	7	710	85	794	900	230	1224	254	28	M20	1092	736	355	35	1535	1548	254	70	140	132	62.5	110	20	74.5	355C
355C	4P & UP	7	710	85	794	900	230	1224	254	28	M20	1092	736	355	35	1535	1578	254	95	170	162	86	140	25	100	355C
400A	4P & UP	7	800	85	894	800	240	1149	280	35	M24	1245	785	400	36	1700	1570	280	110	210	200	100	160	28	116	400A
400C	2P	7	800	85	894	1000	240	1349	280	35	M24	1245	785	400	36	1700	1700	280	70	140	132	62.5	110	20	74.5	400C
400C	4P & UP	7	800	85	894	1000	240	1349	280	35	M24	1245	785	400	36	1700	1770	280	110	210	200	100	160	28	116	400C
450A	4P & UP	7	900	85	994	900	280	1324	315	35	M24	1366	835	450	37	1847	1740	315	125	210	202	114	160	32	132	450A
450C	4P & UP	7	900	85	994	1120	280	1544	315	35	M24	1366	835	450	37	1847	1960	315	125	210	202	114	160	32	132	450C
500A	4P & UP	7	1000	100	1114	1000	280	1418	335	42	M30	1621	895	500	37	2032	1920	335	140	250	240	128	200	36	148	500A
500C	6P & UP	7	1000	100	1114	1250	280	1668	335	42	M30	1621	895	500	37	2032	2170	335	140	250	240	128	200	36	148	500C
560A	6P & UP	7	1180	100	1244	1120	280	1538	355	42	M30	1768	960	560	51	2226	2130	355	160	300	290	147	250	40	169	560A
560C	6P & UP	7	1180	100	1244	1400	280	1818	355	42	M30	1768	960	560	51	2226	2410	355	160	300	290	147	250	40	169	560C
630A	6P & UP	7	1250	132	1406	1250	355	1714	375	48	M36	2038	1046	630	58	2475	2300	375	160	300	290	147	250	40	169	630A
630C	6P & UP	7	1250	132	1406	1600	355	2064	375	48	M36	2038	1046	630	58	2475	2650	375	160	300	290	147	250	40	169	630C
710A	6P & UP	7	1400	180	1488	1400	380	1914	400	48	M36	2210	1087	710	58	2720	2500	400	160	300	290	147	250	40	169	710A

Dimensions in mm

NOTES

1. Tolerance of shaft extension diameter $D = m6$
2. Tolerance of shaft centre height $H = \begin{smallmatrix} 0 \\ -0.05 \end{smallmatrix}$ for F#630 & below $\begin{smallmatrix} 0 \\ -0.08 \end{smallmatrix}$ for F#710 & up
3. Tolerance of key width $F = h9$
4. Usable Shaft Length: EE
5. Anti-friction bearings

HEAD OFFICE

Teco Electric & Machinery Co. Ltd
49 Wu Kong 6 Rd.
Wu-Ku Industrial Park
Taipei County 248
Taiwan ROC
Tel: +886 2 8990 1111
www.teco.com.tw

UNITED STATES

Teco-Westinghouse Motor Company
PO Box 227 (78680-0277)
5100 N.IH35
Round Rock Texas 78681 USA
Tel: +1 512 255 4141
+1 800 873 8326
www.tecowestinghouse.com

CANADA

Teco-Westinghouse
Motors Inc. (Canada)
18060-109th Ave
Edmonton, Alberta T5S 2K2 Canada
Tel: +1 780 444 8933
Fax: (780) 486-4575
24 HR Emergency Pager:
(780) 419-7734
Toll Free: 800-661-4023
Fax Toll Free: 888-USE-TWMI
www.twmi.com

UNITED KINGDOM

Teco Electric Europe Limited
Teco Building Marshall Stevens Way
Trafford Park Manchester
M17 1PP England United Kingdom
Tel: +44 161 877 8025
www.teco.co.uk

GERMANY

Teco Westinghouse
Germany GmbH
Marktstraße 69
37441 Bad Sachsa
Tel: +49 5523 95340
Fax: +49 5523 953424
www.teco-westinghouse.de

SPAIN

Teco Electric Europe Ltd
C/Sancho Dávila 8 4ºF
28028 Madrid Spain
Tel: +34 91 725 1718

AUSTRALIA

Sydney Office
Teco Australia Pty Ltd.
335-337 Woodpark Road
Smithfield NSW 2164 Australia
Tel: +61 2 9765 8118
www.teco.com.au

Melbourne Office
Teco Australia Pty Ltd.
16 Longstaff Road,
Bayswater VIC 3153 Australia
Tel: +61 3 9720 4411

Brisbane Office
Teco Australia Pty. Ltd.
50 Murdoch Circuit,
Acacia Ridge QLD 4110 Australia
Tel: +61 7 3373 9600

Perth Office
Teco Australia Pty Ltd.
28 Belgravia Street,
Belmont WA 6104 Australia
Tel : +61 8 9479 4879

NEW ZEALAND

Teco Newzealand Pty Ltd.
Unit 3 477 Great South Road
Penrose Auckland New Zealand
Tel: +64 9 526 8480

CHINA

Suzhou Teco Electric &
Machinery Co., Ltd
No. 1 Changjiang W.Rd. South-Dam
Industrial Park Liuhe Zhen
Taicang City, Suzhou,
Jiangsu Province, PRC
Tel: +86 512 5361 9901
Fax: +86 512 5396 1058

Wuxi Teco Electric &
Machinery Co., Ltd.
No. 72 Wuxi National
Hi-Tech Industrial Development Zone
New District, Jiang Su, China
Tel: + 86 510 534 2005

Shanghai Office: 12F No. 1800
Zhongshan West Road Shanghai
Tel: +86 21 6440 1477
Fax: +86 21 6440 1791

HONG KONG

Tecoson Industrial Development
(HK) Co Ltd.
Rm 3712 Hong Kong Plaza
186-191 Connaught Rd West
Hong Kong
Tel: +852 2858 3220

JAPAN

Sankyo Co., Ltd.
26th fl. World Trading Center Bldg.
2-4-1 Hamamatsucho Minato-ku
Tokyo Japan 105-6126
Tel: +81 3 3435 9729
Fax: +81 3 3578 8381

SINGAPORE

Teco Electric & Machinery (PTE) Ltd.
18 Chin Bee Drive
Singapore 619865
Tel: +65 6 265 4622
www.teco.com.sg

INDONESIA

P.T. Teco Multiguna Elektro
JL Bandengan Utara No. 83/1-3
Jakarta Utara-14400 Indonesia
Tel: +62 21 662 2201

MALAYSIA

STE Marketing SDN BHD
6 Jalan Firma 2 Kawasan Perind.
Tebrau 1
81100 Johor Bahru Johor Malaysia
Tel: +60 7 354 8008

THAILAND

Teco Electric & Machinery
(Thai) Co. Ltd.
128/1 Soi Watsrivareeno
Moo 7 Bangna-Trad Road Km 18
Bangchalong Bangkok
Samuthprakarn 10540 Thailand
Tel: +662 3371311- 20

