

**INSTRUCTIONS
FOR
THREE PHASE
INDUCTION MOTORS**



TECO

TECO Electric & Machinery Co., Ltd.

INDEX

Page

1. INTRODUCTION.....	2
2. ACCEPTING, INSPECTION, STORAGE, TRANSPORTATION.....	3
2.1 Inspection upon receipt	3
2.2 Storage.....	3
2.3 Transportation.....	6
3. INSTALLATION.....	7
3.1 Site and environment for motor installation.....	7
3.2 Foundation.....	7
3.3 Installation of shaft coupling.....	10
3.4 Installation for belt drive.....	14
3.5 Conveyance with chain or gear.....	16
3.6 Electrical connections.....	16
4. OPERATION.....	18
4.1 Examination before start	18
4.2 Starting operation.....	23
5. MAINTENANCE.....	26
5.1 Major points in regular inspection and maintenance.....	26
5.2 Motor windings.....	27
5.3 Clean the interior of the motor.....	27
5.4 Clean the exterior of the motor.....	28
5.5 Maintenance of anti-friction bearing.....	28
5.5.1 Frequency of relubrication.....	28
5.5.2 Kinds of grease.....	30
5.5.3 Grease quantity.....	30
5.5.4 Re-greasing.....	31
5.5.5 Oil relubrication.....	31
5.5.6 Cleaning and installation of bearings.....	32
5.6 Maintenance of sleeve bearing.....	33
5.6.1 Daily inspections.....	33
5.6.2 Regular examination.....	33
5.6.3 Disassembly.....	34
5.6.4 Reassembly.....	36
5.7 Maintenance of slip ring (for Wound Rotor only).....	37
5.8 Maintenance of non-reverse ratchet mechanism.....	39
6. FAULT FINDING AND RECOGNITION.....	41
7. TECO Worldwide Operations.....	43

1. INTRODUCTION

This and the following instructions address the more common situations encountered in motor installation, operation and maintenance. For the TECO motor warranty to be and to remain in effect, the motor must be installed and operated in strict accordance with the outline drawing, motor nameplates and these instructions and must not be altered or modified in any unauthorized manner.

During these installations and operation of motors in heavy industrial applications there is a danger of live electrical parts and rotating parts. Therefore to prevent injury and/or damage the basic planning work for installation, transport, assembly, operation, etc.... needs to be done and checked by authorized and competent personnel only.

Since these instructions cannot cover every eventuality of installation, operation and maintenance, the following points should however be considered and checked.

- The technical data and information on permissible use such as assembly, connection, ambient and operating conditions given in the related catalogue, operating instructions, nameplates and other production documentation.
- The general erection and safety regulations.
- The local and plant-specific specifications and requirements.
- The proper use of transport, lifting devices and tools.
- The use of personal protective equipment.

Following indications should be observed when reading these instructions.

Safety instructions are marked as follows :



Warning of electric hazards for personnel.



Warning of dangers for personnel.

ATTENTION !

Warning of damage for the motor or installation.

This instruction manual is for **TECHNICAL USE ONLY, NOT FOR COMMERCIAL PURPOSE**. The warranty is limited to coverage expressed in your sales contract. Documentation of storage, transportation, installation and examination, if required, shall be inquired of TECO's service center before start and maintenance.

2. ACCEPTING, INSPECTION, STORAGE, TRANSPORTATION

2.1 Inspection upon receipt

Check the following points upon receipt :

- Are the nameplate ratings identical with what you ordered ?
- Are dimensions and color in compliance with your specifications ?
- Are the nameplate ratings for heater, thermal protector, temperature detector, etc. identical with what you ordered ?
- Is there any damage ?
- Are all accessories and accompanying instruction manuals in good order ?
- Please ensure that the arrowhead indicator really indicates direction of revolution.
- If there are any specific requirements, please ensure they are in conformity with your specification.

2.2 Storage

When motors are not in operation, the following precautionary measures should be undertaken to assure best performance.

2.2.1 Place

- (a) High and dry, well-ventilated without direct sun, dust or corrosive gas.
- (b) Not located near to a boiler or freezer.
- (c) Entirely free from vibration and easy for movements.
- (d) Motors should be put on pallets to prevent moisture.

2.2.2 Well protection

Motors should be well shielded from dust, but under well-ventilated circumstances. For those water-cooling motors or using bearings with water-cooling coils, please make sure the water already dried off to prevent tube corrosion or danger of frost.

2.2.3 Moisture prevention

Since moisture can be very detrimental to electrical components, the motor temperature should be maintained about 3°C above the dew point temperature by providing either external or internal heat. If the motor is equipped with space heaters, they should be energized at the voltage shown by the space heater nameplate attached to the motor. Incandescent light bulbs can be placed within the motor to provide heat. However, if used, they must not be allowed to come in contact with any parts of the motor because of the concentrated hot spot that could result.

2.2.4 Insulation resistance test

Even during storage, the insulation resistance should be kept above the specified values.

- (a) For measurement of insulation resistance and acceptable standard values, please refer to measures stated in 4.1.2 "Measurement of insulation resistance".
- (b) Insulation resistance test should be performed once every three months.

2.2.5 Long period storage

If the motor is not in operation for a long period (one week and above) after installation or has been in operation but stopped for a period of time, the following precautions must be taken.

- (a) Protect the motor as measures stated in 2.2.3.
- (b) Insulation resistance test should be performed as stated in 2.2.4.
- (c) Bearing protection per 2.2.6.
- (d) Operation test should be performed once every three months.
- (e) Storage maintenance is to be documented for warranty data.

2.2.6 Bearing protection

- (a) If the motor has been provided with a shaft shipping brace to prevent shaft movement during transit, it must be removed before operating the motor.

It is very important that this brace be reinstalled exactly as it was originally, before the motor is moved from storage or any time when the motor is being transported. This prevents axial rotor movement that might damage the bearings.

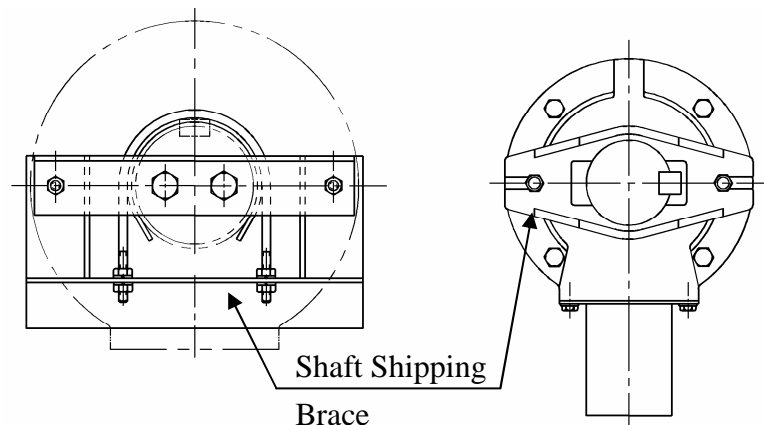

Fig. 1 Shaft shipping brace

- (b) Motors equipped with sleeve bearings are shipped from the factory with the bearing oil reservoirs drained. In storage, the oil reservoirs should be properly filled to the center of the oil level gauge with a good grade of rust inhibiting oil. To keep the bearing journals well oiled and to prevent rusting, the motor shaft should be rotated several revolutions about every month ensuring the shaft does not come to rest in its original position. While the shaft is rotating, it should be pushed to both extremes of the endplay. If the motor is not in operation over six months, dismount the upper cover of sleeve bearing housing and check the anti-corrosion protection.
- (c) Motors with anti-friction bearings are properly lubricated with the correct grade of grease at the factory and no further greasing is required in storage. If the motor is not in operation over three months, add grease to each bearing per lubrication nameplate. The shaft should be rotated several revolutions about every month to maintain proper distribution of the grease within the bearings.

(d) Tilt-pad bearings are a type of sleeve bearing used in special design applications. Due to the nature of this bearing, a loose oil ring for delivering lubricant cannot be provided. Therefore, during the storage interval, oil must be periodically manually introduced into the pads and housing to prevent the occurrence of oxidation of the precision machined components.

- (1) Remove the pipe plug from the bearing cap located above the tilt-bearing shell.
- (2) Pour in approximately one cup of oil every month and rotate the shaft a few revolutions about every two (2) weeks.

For long periods of storage, the oil that accumulates in the housing should be removed.

(e) The bearing assembly parts of motors with oil mist lubrication are put on with anti-rust oil, so they can be preserved for several months in good conditions. The motor should be stored indoor & well-ventilated environment and prevent to contact with contaminated or corrosive air. The following points should be noted :

- (1) During preservation, the Inpro seal can not prevent the moisture to go through into the bearings. Please use the oil mist to lubricate the bearings every two (2) weeks.
- (2) If the color of flow out oil is changed, the bearing should be rusted or having contamination in it. Please contact with us.
- (3) Avoid using grease as it will plug the vent/drain.
- (4) All assembly surfaces are painted with seal bonds, don't disassemble them anytime.
- (5) Don't remove the plugs in vent/drain to prevent the moisture.
- (6) Don't apply any force on the Inpro seal to prevent damage.
- (7) The Inpro seal is a labyrinth type seal. Therefore it can not contain a pressure differential.

2.2.7 Prevent rusting

ATTENTION !

Cares should be taken to keep parts such as fitting surface, key, shaft extension and axial central hole from any collision with foreign matters. Grease should also be generously applied to prevent rusting.

2.3 Transportation

ATTENTION !

To keep the rotating parts of motors from moving, thus preventing damage and scratching during transportation, they should be held securely with a locking device. Remove all transit clamps before operating the motor. It is very important that this device be reinstalled exactly as it was originally, before the motor is moved from storage or any time when the motor is being transported.

The vertical mounting type motors should be transported in the vertical position.



Do not use the hoisting hook/eyebolts to lift more than the motor itself. They are designed to support the motor only.

Make sure the hoisting hook is correctly attached to the eyebolt(s) or lug(s) of the motor and that the eyebolt(s)/lug(s) are fully screwed in before hoisting. Also note such parts as fan cover, ventilation box, bracket, slip-ring, etc. may have their own hoisting lugs which can only carry their own weight. Nothing extra should be attached while hoisting.

Do not twist the steel wires and make sure the eyebolts have been firmly screwed and the sling angle is correct.

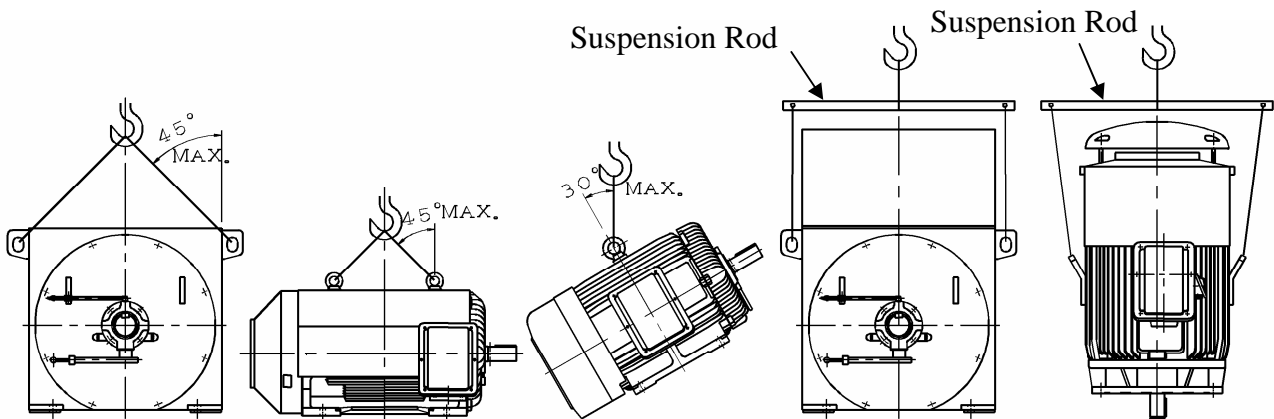

Fig. 2

3. INSTALLATION

3.1 Site and environment for motor installation

3.1.1

Standard environment and site conditions for the installation of motors are usually set as follows :

- (a) Ambient temperature : $-20 \sim +40 \text{ }^{\circ}\text{C}$
- (b) Humidity : Relative humidity shall be below 95%RH for totally-enclosed types, and below 80%RH for semi-enclosed types.
- (c) Elevation : Below 1000 meters.
- (d) Harmful gases, liquids, dusts, high moisture should be absent.
- (e) Foundations should be strong and free of vibration.

For those water-cooling motors or using bearings with water-cooling coils, the ambient temperature shall not be below 0°C to prevent danger of frost. If there are any special environmental conditions, please inform us upon ordering.

3.1.2 Ventilation and space

- (a) Installation area should be well-ventilated.
- (b) The installation space should be large enough to facilitate heat dissipation and maintenance.

3.2 Foundation

Motor manufacturer is not responsible for the foundation design. Motor weight, thrust load, twisting moments, seismic forces and other external applied loads must be considered in foundation design.

3.2.1 Reactions of horizontal motor

For a horizontal motor with four hold down bolts, the reactions necessary for foundation design are as follows – kgs per bolt at centerline of hold down bolt holes :

- (a) Static weight = motor weight / bolt number
- (b) Rated motor torque (T_R) , reactions = motor weight/bolt number $\pm T_R/2L$
- (c) Maximum motor torque (T_{max}) ,
reactions = motor weight/bolt number $\pm T_{max}/2L$

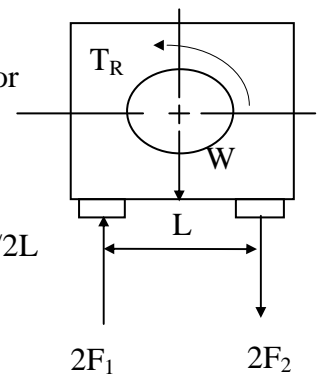

Fig. 3

3.2.2 Soleplate & common bed

Use rigid and solid soleplate or common bed as foundation.

ATTENTION !

For best motor performance, it is advisable to use a soleplate or common bed, particularly when using a shaft coupling.

If the soleplate or common bed doesn't have enough stiffness, the critical speed of motors or equipment will then be changed. This change may cause a large vibration (resonance) and decrease the life of machines.

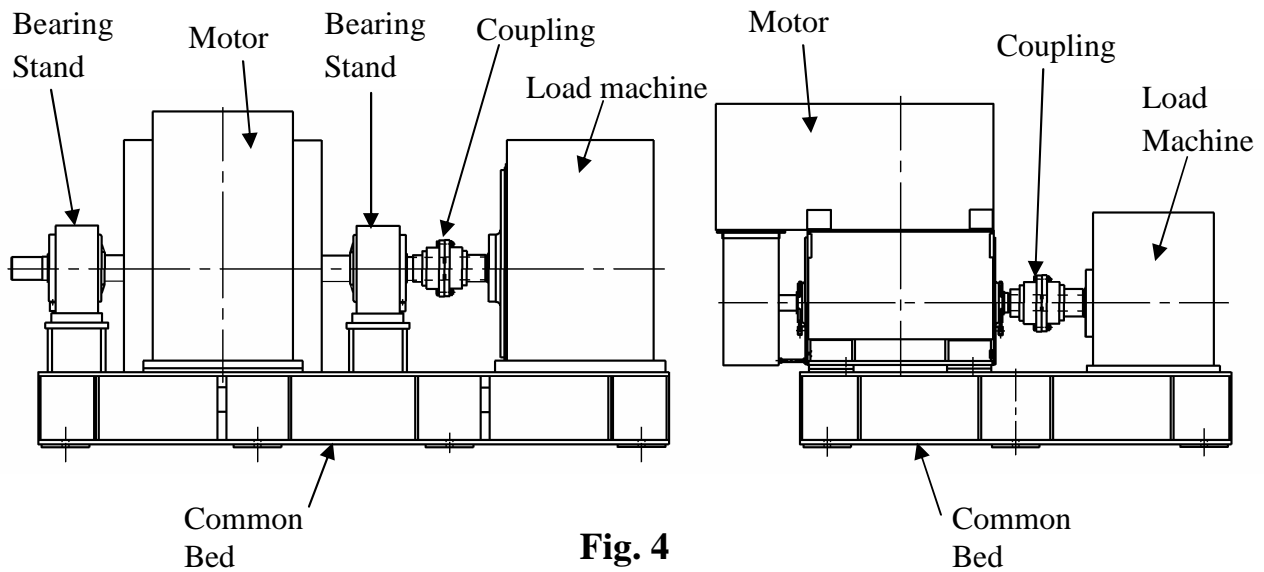

Fig. 4

3.2.3 Installation

- (a) Select an appropriate foundation surface for the soleplate or common bed which will be considered the ultimate level.
- (b) Align the position of the common bed with reference to that level.
- (c) Align the level accuracy at least at four points such as bearing mounting, shaft extension etc. The accuracy should be within 0.04mm (1.5mil).
- (d) Soleplate or common bed should be embedded in concrete foundation as illustrated in Fig.5. Stiff pads should also be installed beneath the wedges which are welded together at various spots about 400-500mm (15-20inches) apart etc., to enable foundation to carry evenly the weight of the whole motor.
- (e) The base should be sturdy and rigid to keep it flat and level.
- (f) Make sure the mortar and concrete are completely dry, and the precision of the level is acceptable, then set the motor on the mounting foundation.
- (g) Accurately install shaft couplings, belt sheaves etc., then weld the wedges solid to prevent untoward change in position.

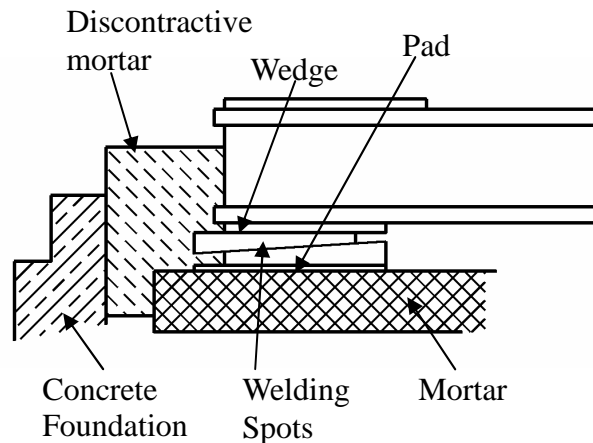

Fig. 5

3.2.4 The foundation of vertical induction motor (Also the foundation of pump)

- (a) Foundation of motor/pump must be rigid and secure to provide adequate support. There must be no vibration, twisting, misalignment etc. due to inadequate foundations.
- (b) A massive concrete foundation is preferred in order to minimize vibration. Rigidity and stability are enhanced by prop plate and foundation bolt. As shown in Fig.6 and Fig.7.

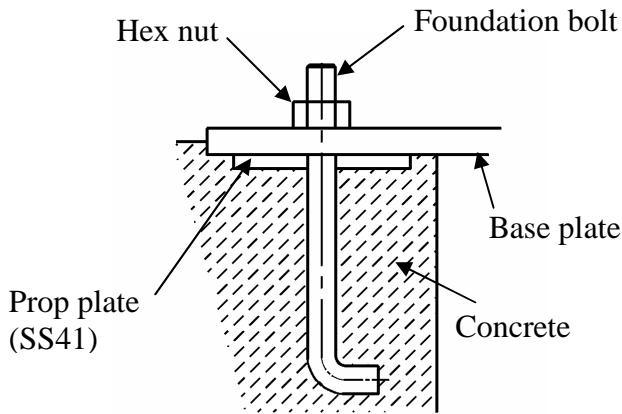

Fig. 6

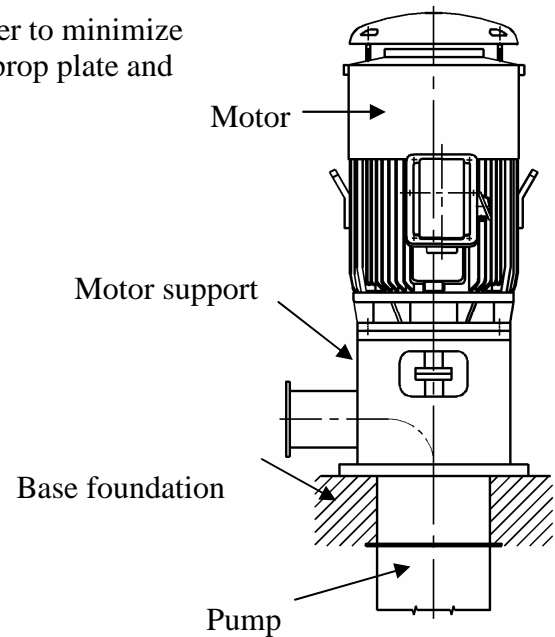

Fig. 7

3.2.5 Installation of vertical motor

- (a) All mounting surfaces must be clean and level.
- (b) Foundation must be leveled at least at 4 points and guaranteed to be below 0.04mm flat and level.
- (c) Make sure the mortar and concrete are completely dry, and the precision of the level is acceptable, then set the motor on the mounting foundation.
- (d) Accurately install shaft couplings.

3.3 Installation of shaft coupling

3.3.1 General

ATTENTION !

Motors must always be accurately aligned, and this applies especially where they are directly coupled.

Incorrect alignment can lead to bearing failure, vibration and even shaft fracture. As soon as bearing failure or vibration is detected, the alignment should be checked.

3.3.2 Mounting procedure

Field application of a coupling to the motor shaft should follow the procedures recommended by the coupling manufacturer. The motor shaft extension must not be subjected to either extreme heat or cold during coupling installation.

3.3.3 Safety attention

ATTENTION !

Basically, the coupling should be heated and pushed onto the shaft extension with slight axial force. Do not hammer coupling to prevent bearing damage.

3.3.4 End-play

Although the sleeve bearings are equipped with thrust faces, these are intended only to provide momentary axial restraint of rotor movement either during start-up or when operating the motor disconnected from the driven equipment. They must not be operated under a constant thrust load unless they were originally designed for this condition.

Motors with either sleeve or anti-friction bearings are suitable for connection to the driven load through a flexible coupling. Coupling solidly to the load is not acceptable. With sleeve bearings, the flexible coupling should be of the limited end float type to prevent the possibility of any end thrust from the load being transmitted to the motor bearings, which could cause bearing damage.

The recommended limits of end float for couplings are as follows :

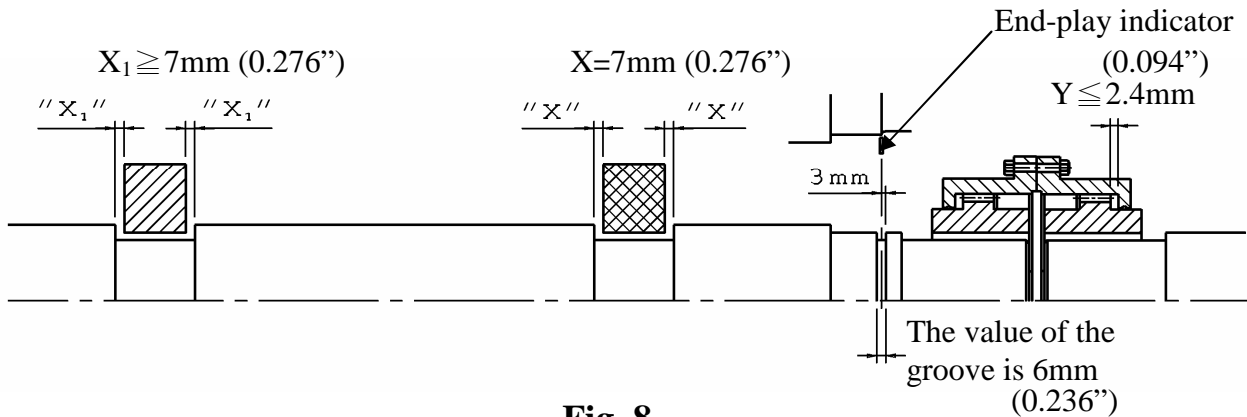

Fig. 8

- When the motor is in operation after installation, be sure that the end-play indicator is within the 6mm of the groove on the shaft or aligned to the shaft shoulder immediately outboard of the drive-end bearing to assure there is low friction between shaft and bearing.
- Unless otherwise specified, the designed end-play value X of the groove for TECO motors in general is within 7mm (0.276 inches) as illustrated in Fig. 8. In essence, the end-play indicator is adjusted to point at the center of the groove or the drive-end shaft shoulder; thus X equals to $7 \pm 1\text{mm}$ (0.276 ± 0.039 inches) or so, and the end-play value (Y) of the couplings should equal or be smaller than 2.4mm (0.094 inches).
- If the desired value Y is greater than 3mm (0.118 inches) caused for instance by a thrust load and/or load machine with large end-play, please inform us when ordering.

3.3.5 Thermal growth

In aligning the motor (and rotor) axially with the driven equipment, consideration should be given not only to the end-play indicator position but also to axial shaft expansion and increase in shaft centerline height due to thermal effects. In general, the axial shaft growth for motors can be disregarded since neither bearing is fixed and any shaft growth due to temperature increase will produce an elongation away from the coupling.

Shaft height growth (change in shaft centerline elevation) for TEFC machines can be calculated as follows :

$$\Delta = (0.0005) \times (\text{motor foot to shaft centerline dimension})$$

For non-TEFC machines, divide this number by 2.

3.3.6 Alignment

It is desirable, in normal operation, that the motor operate on its magnetic center, so that no axial force is exerted on the coupling.

The motor shaft and the driven shaft should be aligned within the following tolerances in both angular and parallel alignment :

Unit : mm

TIR	Range of rotating speed	Solid coupling	Flexible coupling
C	2500rpm and above	0.03	0.03
	Below 2500rpm	0.04	0.05
A	2500rpm and above	0.03	0.03
	Below 2500rpm	0.03	0.04

Angular misalignment is the amount by which the centerlines of driver and driven shaft are skewed. It can be measured using a dial indicator set up as shown in Fig.9. The couplings are rotated together through 360 degrees so that the indicator does not measure run out of the coupling hub face. The shafts should be forced against either the in or out extreme of their end float while being rotated.

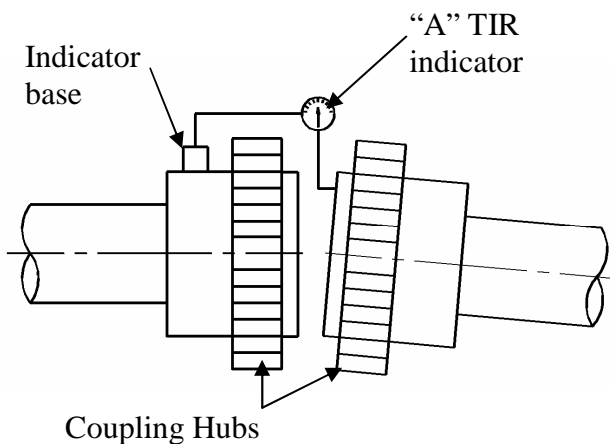

Fig. 9

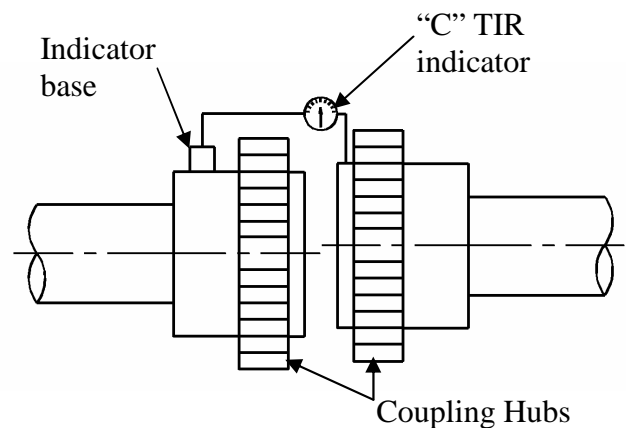

Fig. 10

Parallel misalignment is the amount by which the centerlines of the driver and driven shafts are out of parallel. It can be measured using a dial indicator set up as shown in Fig.10. Again, the couplings are rotated together through 360 degrees so that the indicator does not measure runout of the coupling hub outside diameter.

TIR = Total indicator reading (by dial indicator)

3.3.7 Dowel

After the motor has been properly aligned with the driven equipment and the hold-down bolts have been installed and tightened, for motors with fabricated frame, at least two dowel pins should be installed in two diagonally opposite motor feet.

3.3.8 Installation of shaft coupling (Vertical hollow shaft motor only)

Bolted coupling as Fig.11

- (a) Bearings are provided to absorb some upward shaft thrust when the coupling is fitted.
- (b) The coupling is fastened with bolts.
- (c) This coupling type is not auto-release type.

Note : Standard high thrust motors can absorb momentary upthrust load up to 30% of the standard downthrust load. If the upthrust is long duration (over 10 seconds) and/or exceeds 30% of the standard high thrust rating, special design arrangements are required and a standard motor is not suitable.

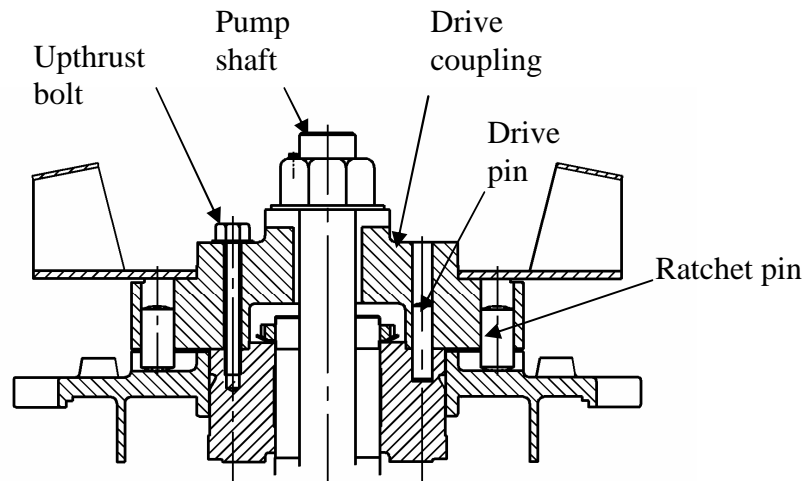

Fig. 11

3.3.9 Non-reverse ratchet/coupling, as Fig. 11 (If necessary)

The non-reverse coupling is also a bolted type and,

- (a) It prevents the pump and motor from rotating in the reverse direction.
- (b) It also prevents damage from over speeding and damage to pump shaft and bearings.
- (c) The ratchet pins are lifted by the ratchet teeth and are held clear by centrifugal force and friction as the motor comes up to speed.
- (d) When power is removed, speed decreases, and the pins fall. At the instant of reversal, a pin will catch in a ratchet tooth and prevent backward rotation.
- (e) When installing the non-reverse coupling, do not use lubricant. Lubrication will interfere with proper operation. The top half of the coupling should seat solidly on the lower half and the pins should touch the bottom of the pockets between the teeth in the plate.
- (f) As with the bolted coupling, the upthrust capabilities are 30% of the standard high thrust rating for downthrust.

ATTENTION !

Do not apply non-reverse ratchets on applications in which the pump reversal time from shutdown (the instant the stop button is pressed) to zero speed is less than one second.

3.3.10 Removal of redundant shaft key

When the length of coupling hub is different from the length of shaft key, the motor may have a high vibration level due to this unbalance condition. The removal of redundant shaft key is necessary, shown as Fig.12.

Method (1) :

After installing the coupling, use a grinding wheel to remove the redundant key (hatch area).

Method (2) :

Before installing the coupling, calculate the different length between coupling hub and shaft key, then cut the half of this different value (hatch area) to achieve approximate-balance condition.

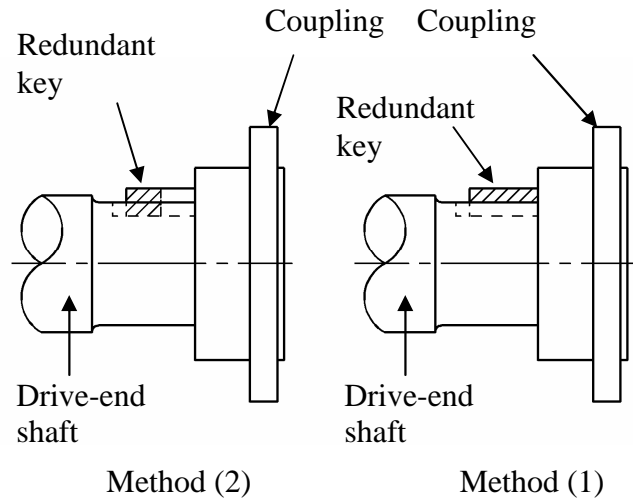

Fig. 12

3.4 Installation for belt drive

In general, power transmission through direct flexible coupling is appropriate for large motors. Such motors are not suitable for belt, chain or gear connection unless specially designed for such service. However, for small and medium motors of which outputs within the ranges shown on table below, it is acceptable to use belt transmission as indicated. Beyond these ranges, do not apply belt sheaves unless specially designed.

3.4.1 Diameter of sheaves

The diameter ratio between conveyance sheaves should not be greater than 5 to 1 for flat belts, and 8 to 1 for V-belt. It is also advisable to limit the belt velocity to under 35 m/sec to limit belt abrasion and vibration. The smaller the outer diameter of the V-belt sheave, the greater the shaft bending stress will be. If the bending stress is in excess of the shaft fatigue stress, the shaft may break. Therefore, please inform us when you have decided the size of the sheaves and the length of the belts upon ordering.

ATTENTION !

Place the sheave and belt as close as possible to the motor body (it is advisable to make x as shown in Fig.13 equal to 0) to reduce the bending moment and improve shaft life.

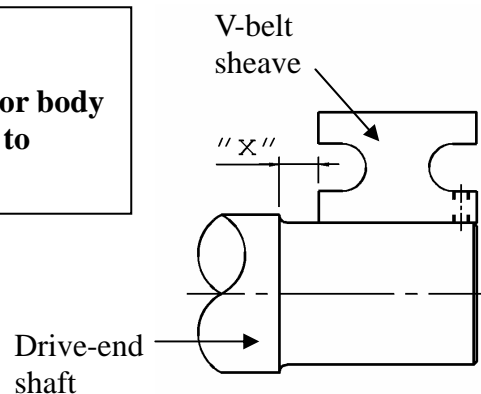

Fig. 13

3.4.2 Table of belt-sheave application for general electric motors

Output (kW)			V-Belt Sheave							
			Conventional V-Belt				Narrow V-Belt			
4P	6P	8P	V-Belt Type	Number of Belts	Min. PCD (mm)	Max. Width (mm)	V-Belt Type	Number of Belts	Min. PCD (mm)	Max. Width (mm)
11	--	--	B	4	160	82	3V	4	125	48
--	11	--	B	5	170	101	3V	5	140	59
--	--	11	B	5	190	101	3V	6	160	69
15	--	--	B	5	170	101	3V	6	125	69
--	15	--	B	5	224	101	3V	6	160	69
--	--	15	C	4	224	111	5V	3	180	60
18.5	--	--	B	5	200	101	3V	6	140	69
--	18.5	--	C	4	224	111	5V	3	180	60
--	--	18.5	C	5	224	136	5V	4	180	78
22	--	--	B	5	224	101	3V	6	160	69
--	22	--	C	5	224	136	5V	4	180	78
--	--	22	C	5	250	136	5V	4	200	78
30	--	--	C	5	224	136	5V	4	180	78
--	30	--	C	5	265	136	5V	4	224	78
--	--	30	C	6	265	162	5V	5	224	95
37	--	--	C	6	224	162	5V	4	200	78
--	37	--	C	6	265	162	5V	4	224	78
--	--	37	C	7	280	187	5V	5	250	95
45	--	--	C	6	265	162	5V	4	224	78
--	45	--	C	7	280	187	5V	5	224	95
--	--	45	C	7	315	187	5V	6	250	113
55	--	--	C	7	265	187	5V	5	224	95
--	55	--	C	8	300	213	5V	6	250	113
--	--	55	D	5	355	196	5V	6	280	113
75	--	--	C	8	315	213	5V	6	250	113
--	75	--	D	6	355	233	5V	6	315	113
--	--	75	D	6	400	233	5V	6	355	113
--	90	--	D	6	400	233	5V	6	355	113
--	--	90	D	6	425	233	8V	4	355	124
--	110	--	D	7	400	270	8V	4	355	124
--	132	110	D	7	450	270	8V	4	400	124
--	160	132	D	9	450	344	8V	4	450	124

3.5 Conveyance with chain or gear

3.5.1 Loading capacity

Make sure the loading capacity of shaft and bearings is appropriate for the size and installation position (overhung) of chain and gear. If necessary, please contact us to ensure the shaft and bearings will meet your requirements.

3.5.2

Pay close attention to ensure the parallelism of shafts.

3.5.3

The teeth of couplings should be correctly and precisely matched; the force conveyance centers should lie on the same line.

3.5.4

There should be no skip, jumping, vibration or unusual noises.

ATTENTION !

Do not hammer the conveyance devices such as couplings, belt sheaves, chain wheels, gears etc. onto the shaft. Those shaft fitments should be fitted and removed only by means of suitable devices. Heat shrinking may be a better alternative to avoid damaging bearings and other components.



The exposed rotating parts should be covered to prevent accidents.

3.6 Electrical connections

All interconnecting wiring for controls and grounding should be in strict accordance with local requirements such as the USA National Electrical Code and UK IEE wiring regulations.

Wiring of motor and control, overload protection and grounding should follow the instructions of connection diagrams attached.

3.6.1 Power

The rated conditions of operation for the motor are as shown on the nameplate. Within the limits, given below, of voltage and frequency variation from the nameplate values, the motor will continue to operate but with performance characteristics that may differ from those at the rated conditions :

+/- 10% of rated voltage

+/- 5% of rated frequency

+/- 10% combined voltage and frequency variation so long as frequency variation is no more than +/- 5% of rated

Operating the motor at voltages and frequencies outside of the above limits can result in both unsatisfactory motor performance and damage to or failure of the motor.

3.6.2 Main lead box

The main lead box furnished with the motor has been sized to provide adequate space for the make-up of the connections between the motor lead cables and the incoming power cables.



The bolted joints between the motor lead and the power cables must be made and insulated in a workman-like manner following the best trade practices.

3.6.3 Grounding

Either fabricated motors or fan cooled cast frame motors are all provided with grounding pads or bolts.



The motor must be grounded by a proper connection to the electrical system ground.

3.6.4 Rotation direction

The rotation direction of the motor will be as shown by either a nameplate on the motor or the outline drawing. The required phase rotation of the incoming power for this motor rotation may also be stated. If either is unknown, the correct sequence can be determined in the following manner : While the motor is uncoupled from the load, start the motor and observe the direction of rotation. Allow the motor to achieve full speed before disconnecting it from the power source. Refer to the operation section of these instructions for information concerning initial start-up. If resulting rotation is incorrect, it can be reversed by interchanging any two (2) incoming cables.

3.6.5 Auxiliary devices

Auxiliary devices such as resistance temperature detectors, thermocouples, thermoguards, etc., will generally terminate on terminal blocks located in the auxiliary terminal box on the motor. Other devices may terminate in their own enclosures elsewhere on the motor. Such information can be obtained by referring to the outline drawing. Information regarding terminal designation and the connection of auxiliary devices can be obtained from auxiliary drawings or attached nameplates.

If the motor is provided with internal space heaters, the incoming voltage supplied to them must be exactly as shown by either a nameplate on the motor or the outline drawing for proper heater operation.



Caution must be exercised anytime contact is made with the incoming space heater circuit as space heater voltage is often automatically applied when the motor is shutdown.

4. OPERATION

4.1 Examination before start

4.1.1 Wiring check

When motors are installed in good manner, ensure the wiring is according to the diagram. Also, the following points should be noted :

- (a) Make sure all wiring is correct.
- (b) Ensure the sizes of cable wires are appropriate and all connections are well made for the currents they will carry.
- (c) Ensure all connections are properly insulated for the voltage and temperature they will experience.
- (d) Ensure the capacity of fuse, switches, magnetic switches and thermo relays etc. are appropriate and the contactors are in good condition.
- (e) Make sure that frame and terminal box are grounded.
- (f) Make sure that the starting method is correct.
- (g) Make sure switches and starters are set at their right positions.
- (h) Motor heaters must be switched off when the motor is running.

4.1.2 Measurement of insulation resistance



During and immediately after measuring, the terminals must not be touched as they may carry residual dangerous voltages. Furthermore, if power cables are connected, make sure that the power supplies are clearly disconnected and there are no moving parts.

- (a) For rated voltage below 1000V, measured with a 500VDC megger.
For rated voltage above 1000V, measured with a 1000VDC megger.
- (b) In accordance with IEEE 43-2000, there are three recommendation minimum insulation resistance values. These values corrected to 40°C are :
 - (1) kV+1 in Megohms for most windings made before 1970, all field windings and windings not otherwise described.
 - (2) 100 Megohms for most DC armatures and AC windings built after about 1970 with form wound coils.
 - (3) 5 Megohms for machines with random wound stator coils and for form wound coils rated below 1kV.

ATTENTION !

After measurement the winding must be grounded for discharging the winding.

(c) On a new winding, where the contaminant causing low insulation resistance is generally moisture, drying the winding through the proper application of heat will normally increase the insulation resistance to an acceptable level. The following are several accepted methods for applying heat to a winding :

- (1) If the motor is equipped with space heaters, they can be energized to heat the winding.
- (2) Direct current (as from a welder) can be passed through the winding. The total current should not exceed approximately 20% of rated full load current. If the motor has only three leads, two must be connected together to form one circuit through the winding. In this case, one phase will carry the full applied current and each of the others, one-half each. If the motor has six leads (3 mains and 3 neutrals), the three phase should be connected into one series circuit.



Ensure there is adequate guarding so live parts cannot be touched.

- (3) Heated air can be either blown directly into the motor or into a temporary enclosure surrounding the motor. The source of heated air should preferably be electrical as opposed to fueled (such as kerosene) where a malfunction of the fuel burner could result in carbon entering the motor.

ATTENTION !

Caution must be exercised, when heating the motor with any source of heat other than self contained space heaters, to raise the winding temperature at a gradual rate to allow any entrapped moisture to vaporize and escape without rupturing the insulation. The entire heating cycle should extend over 15-20 hours.

Insulation resistance measurements can be made while the winding is being heated. However, they must be corrected to 40°C for evaluation since the actual insulation resistance will decrease with increasing temperature. As an approximation for a new winding, the insulation resistance will approximately halve for each 10°C increase in insulation temperature above the dew point temperature.

- (d) Should the resistance fail to attain the specified value even after drying, careful examination should be undertaken to eliminate all other possible causes, if any.

4.1.3 Power source

- (a) Ensure the capacity of the power source is sufficient.
- (b) Ensure the supply voltage and frequency ratings are identical to those on the nameplate.
- (c) Voltage variation should be confined to within $\pm 10\%$ of the rated value and the phase to phase voltages should be balanced.

4.1.4 Bearing lubrication

- (a) For sleeve bearing motors, the oil reservoir must be filled with oil to the correct level. On self-lubricated bearings, the standstill oil level will be at the center of the oil gauge. The proper oil is a rust and oxidation inhibited, turbine grade oil. Refer to the lubrication nameplate for the recommended viscosity.
- (b) Motors which are supplied with provision for flood lubrication have an inlet orifice to meter the oil flow to the bearing. Refer to the outline drawing for these values. If the supply pressure does not match that stated on the outline, the orifice size must be adjusted to produce the specified flow rate. The drain adapter (also provided) has a weir plate fixed to the inside of the pipe to permit the establishment of the proper oil level. This weir plate must be located at the bottom of the pipe and must be parallel to the plane of the motor feet. To ensure optimum flow, the drain line should be vented to the atmosphere.

Oil inlet temperature :	Normal below	50°C (122°F)
	Alarm	60°C (140°F)
	Trip	65°C (149°F)

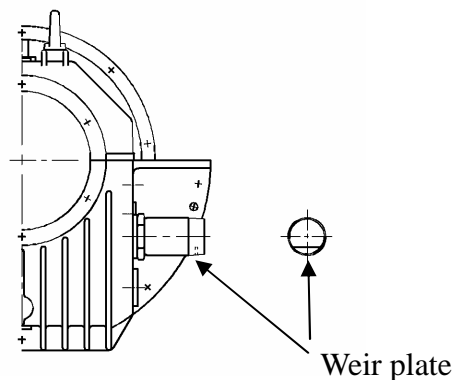

Fig. 14

- (c) If the motor is in storage for over three (3) months, refilling of some new oil should be undertaken before operation to prevent bearing damage due to dry friction. The oil level should be kept at the center of the oil gauge. If necessary, drain some oil after refilling.
- (d) Grease lubricant type
- (1) The bearings have been well greased at factory before delivery. However, regreasing is required if a significant period has elapsed between manufacture and use or in storage. Fill new grease until it overflows and the old grease is entirely replaced.
 - (2) Unless otherwise specified, SHELL Alvania RL3 is the standard applied to TECO motors.
 - (3) If roller bearing is used, add a small quantity of grease when abnormal sound occurred from the bearings. If this sound, such as shi-shi or thru-thru, disappears temporarily after regreasing, it is normal condition can operate as it is, as long as the temperature rise of the bearing is normal.

4.1.5 Oil-mist lubrication motors

Unless otherwise specified, Inpro seal is the standard applied to TECO motor.

(a) Before operation :

Please check the rotor & stator parts of the Inpro seal, and make sure that they don't contact with each other. The 0.03mm thickness gap gauge is suggested to inspect the gap between rotor and stator as shown in Fig.15. If they are touched in one side, it means that this seal is in the wrong position. You can use a wooden or rubber hammer to adjust this seal gently. If this can't be done, this seal may be failed and have to be checked. Please contact with us.

(b) Lubricant :

Please use ISO VG68 or the same viscosity oil except lubrication nameplate specified others.

(c) About the oil mist lubrication generation system :

The users have to prepare an oil mist lubrication system, and apply suitable inlet oil quantity and pressure. Please follow the instruction of oil mist lubrication system what you used. Avoid high oil pressure going into the inside of the motor to damage the insulation or oil leakage.

(d) Operation :

Before first operation or long time without running, please turn on the oil mist lubrication system at least 5 hours to lubricate the bearings. If you use the central control system, the mist system shall operate continuously for a minimum of 48 hours. After making sure that the pressure is stable and flow out oil is in good conditions, then you could operate this motor.

(e) Appendix :

Fitting or reclassifier of oil-mist lubrication system :

Reclassifiers or fittings are devices which convert small particle-size dry mist to larger particle sizes which can lubricate bearings. Please use correct fittings or reclassifiers.

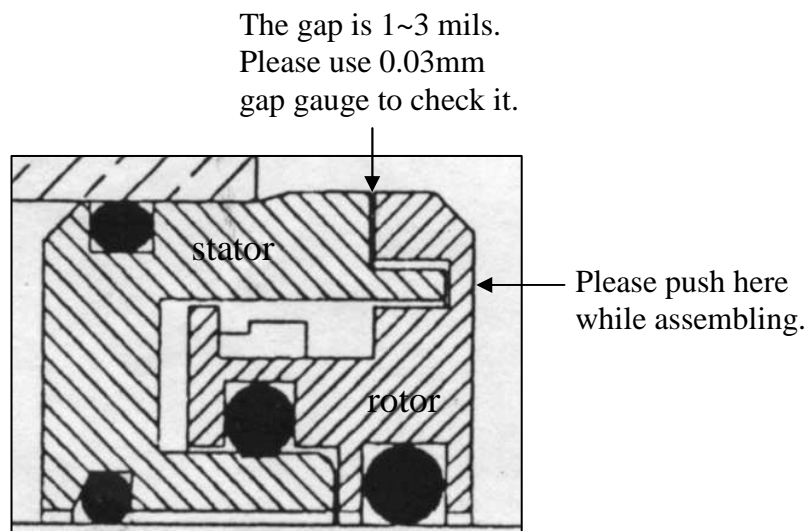

Fig. 15

4.1.6 Cooling water for the cooler on water-cooled motors

Make sure the quality, volume and inlet temperature of cooling water for the motors are normal before the machine is in operation.

Water : General tower water or industrial water, the suspension solid shall below $20 \mu\text{m/l}$

Volume : Please see outline drawing

Inlet temperature : Normal below 30°C (86°F) ; above 5°C (41°F)

Alarm 35°C (95°F)

Trip 40°C (104°F)

Special temperature settings will be noted in outline drawings.

4.1.7 Remove all locks

ATTENTION !

Make sure all locks which fasten the movable parts of the motors during transportation are dismantled and the shaft can rotate freely.

4.1.8 Clean before starting

ATTENTION !

Ensure there are no foreign matters or tools inside the motors before starting motors.

4.1.9 Transmission system check

Make sure the transmission system, including belts, screws, bolts, nuts and set pins are in good condition.



The keys fitted to the shaft extensions are held by plastic tape only to prevent them falling out during transportation or handling. The shaft key shall be removed to avoid flying out, when the motor is operated prior to the couplings etc. being fitted to the shaft extension.

4.1.10 Test run

Make sure the items above are examined. Test the motor running with or without load. Record and check according to "Maintenance" at 15 minutes intervals during the first three hours of operation. Then regular examinations should take place at longer intervals. If all goes well the motor can be classified as "in good order".

4.2 Starting operation

4.2.1 Starting load

Initially run the motor unloaded prior to coupling to other machines. Unless otherwise specified, a motor usually starts with light load which is then gradually increased proportional to the square of speed and at last reach 100% load at full load speed.

4.2.2 Starting

Too frequent starts can harm the motors. The following restrictions should be observed :

- (a) Motor can be restarted should the initial start fail. Two starts are generally permissible when the motor is cold.
- (b) Motor can be started only once when it is at normal running temperature.
- (c) Should additional starts be necessary beyond the conditions stated above, the following restrictions should be noted :
 - (1) Let the motor cool down for 60 minutes before restarting, fully loaded.
 - (2) Let the motor cool down for 30 minutes before restarting, unloaded.
 - (3) Two inching starts can be regarded as one normal start.
- (d)

ATTENTION !

**If the motor rotor fails to start turning within one or two seconds, shut off the power supply immediately.
Investigate thoroughly and take corrective action before attempting a restart.**

Possible reasons for not starting are :

- (1) Too low a voltage at the motor terminals.
- (2) The load is too much for the rotor to accelerate.
- (3) The load is frozen up mechanically.
- (4) All electrical connections have not been made.
- (5) Single phase power has been applied.
- (6) Any combination of the above.

4.2.3 Rotating direction

- (a) Most TECO motors are bi-directional. However, when some special types, such as high speed 2P, certain large capacity motors, those with a non-reverse ratchet etc. should rotate in one direction, please ensure the rotation is in conformity with the directional arrow-mark shown on the attached nameplate.
- (b) To reverse a bi-directional motor, cut the power and wait until the motor stops. Then interchange any two of the three phases.

4.2.4 Power source, Voltage, Current

- (a) Ensure the voltage and frequency of the power source are identical to the ratings shown on the nameplate.
- (b) Voltage variation should be confined to within $\pm 10\%$ of the rating and the three phase voltages should be in full balanced.
- (c) Ensure the motor phase currents, when without load, are within $\pm 5\%$ of the average values.

4.2.5 Frequency

Frequency variation should be confined to within $\pm 5\%$ of the rating. The aggregate variation of voltage and frequency should be confined to within $\pm 10\%$ of the absolute value of the ratings.

4.2.6 Starting time and unusual noises

ATTENTION !

Starting time is longer for the motors with large inertia. However, if starting time is longer than usual or if there is difficulty in starting, or there is abnormal noise, do not run the motor and refer to TECO.

4.2.7 Sleeve bearing oil rings (sleeve bearing types only)

As the oil ring is used to carry lubricant to sleeve bearings, frequently check to ensure the oil ring is in motion.

4.2.8 Bearing temperature rise

Following the initial start-up, the bearing temperatures should be closely monitored. The rate of rise in bearing temperature is more indicative of impending trouble than is the actual temperature.

ATTENTION !

If the rate of rise in temperature is excessive or if the motor exhibits excessive vibration or noise, it should be shut down immediately and a thorough investigation made as to the cause before it is operated again.

If the bearing temperature rise and motor operation appear to be normal, operation should continue until the bearing temperatures stabilize.

Recommended limits on bearing temperature are as follows :

Sleeve Bearings.	Alarm temperature.	Trip temperature
• By permanently installed detector	90°C (194°F)	95°C (203°F)
Anti-Friction Bearings.		
• By permanently installed detector	95°C (203°F)	100°C (212°F)

ATTENTION ! (For sleeve bearing)

- (1) It must be noted that when operating flood lubricated sleeve bearings without outside lubrication supplied, the bearing temperature must not be allowed to exceed 85°C total temperature.**
- (2) Under normal condition, for the self-lube bearing, the rate of temperature rise should be from 11°C to 14°C for the first ten (10) minutes after starting up and approximately 22°C at thirty (30) minutes. The rate of bearing temperature rise is a function of the natural ventilation and operating conditions.**
- (3) When the rate of bearing temperature rise is less than 1°C per half hour, the bearing temperature is considered to be stabilized.**
- (4) If the total bearing temperature exceeds 95°C, the motor should be shut down immediately.**

4.2.9 Noise and Vibration

ATTENTION !

Any abnormal noise or vibration should be immediately investigated and corrected. Increased vibration can be indicative of a change in balance due to mechanical failure of a rotor part, a stator winding problem or a change in motor alignment.

4.2.10 Recommendation of winding operating temperature settings

The limit temperatures can be set 10K higher than the operating temperature at maximum load and ambient temperature. When B rise (80°C) of winding temperature is specified at standard ambient temperature (40°C), the recommendation operating temperature settings as follows :

	Alarm	Trip
Service Factor 1.0	130°C (266°F)	150°C (302°F)
Service Factor 1.15 (when specified)	155°C (311°F)	165°C (329°F)

5. MAINTENANCE

5.1 Major points in regular inspection and maintenance



For safety, maintenance and repairs must only be carried out by properly trained personnel.



Some testing, such as insulation resistance, usually requires the motor to be stopped and isolated from power supply(ies).

Routine inspection and maintenance are usually performed by looking, listening, smelling and simple meters.



High temperature may arise under operating conditions on the motor surfaces, so that touching should be prevented or avoided.

Keep away from moving and live parts.

Unless deemed necessary, do not remove guards whilst assessing the motor.

Timely replacement of worn parts can assure longevity and prevent breakdown.

Routine inspection and regular inspection and maintenance are important in preventing breakdown and lengthening service life.

Owing to the varied time and circumstances, motors are used, it is difficult to set the items and periods for regular inspection and maintenance. However, as a guide it is recommended to be performed periodically according to factory maintenance program. Generally, the inspection scope determined by the following factors :

- (a) Ambient temperature.
- (b) Starting and stopping frequency.
- (c) Troublesome parts usually affecting motor functions.
- (d) Easily abraded parts.
- (e) The important position of motor in the operational system of a factory should be duly recognized. Therefore, its health and wellbeing should be fully protected, especially when it is operating in severe conditions.

5.2 Motor windings

- (a) Measurement of insulation resistance and standards to determine quality of insulation resistance, please refer to measures stated in 4.1.2 "Measurement of insulation resistance".
- (b) Inspection of coil-ends :
 - (1) Grease and dust accumulated on coils may cause insulation deterioration and poor cooling effect.
 - (2) Moisture must not accumulate. Keep coils warm when motor is not in use if moisture can be seen.
 - (3) Discoloring. This is mainly caused by overheat.
- (c) Ensure no untoward change of wedges from original position.
- (d) Ensure the binding at the coil end is in its normal position.

5.3 Clean the interior of the motor

- (a) After a motor is in operation for some time, accumulation of dust, carbon powder and grease etc., on the inside is unavoidable, and may cause damage. Regular cleaning and examination is necessary to assure top performance.
- (b) Points to note during cleaning :
 - (1) If using compressed air or a blower :
 - a) Compressed air should be free of moisture.
 - b) Maintain air pressure at 4 kg/cm², since high pressure can cause damage to coils.
 - (2) Vacuum

Vacuum cleaning can be used, both before and after other methods of cleaning, to remove loose dirt and debris. It is a very effective way to remove loose surface contamination from the winding without scattering. Vacuum cleaning tools should be non-metallic to avoid any damage to the winding insulation.
 - (3) Wiping

Surface contamination on the winding can be removed by wiping using a soft, lint-free wiping material. If the contamination is oily, the wiping material can be moistened (not dripping wet) with a safety type petroleum solvent.

In hazardous locations, a solvent such as inhibited methyl chloroform may be used, but must be used sparingly and immediately removed. While this solvent is non-flammable under ordinary conditions, it is toxic and proper health and safety precautions should be followed while using it.

ATTENTION !

Solvents of any type should never be used on windings provided with abrasion protection. Abrasion protection is a gray, rubber-like coating applied to the winding end-turns.



Adequate ventilation must always be provided in any area where solvents are being used to avoid the danger of fire, explosion or health hazards. In confined areas (such as pits) each operator should be provided with an air line respirator, a hose mask or a self-contained breathing apparatus. Operators should wear goggles, aprons and suitable gloves. Solvents and their vapors should never be exposed to open flames or sparks and should always be stored in approved safety containers.

- (4) Keep core ducts completely clean. The difference in temperature rise could be around 10°C before and after cleaning.

5.4 Clean the exterior of the motor

- (a) On open ventilated motors, screens and louvers over the inlet air openings should not be allowed to accumulate any build-up of dirt, lint, etc. that could restrict free air movement.

ATTENTION !

Screens and louvers should never be cleaned or disturbed while the motor is in operation because any dislodged dirt or debris can be drawn directly into the motor.

- (b) If the motor is equipped with air filters, they should be replaced (disposable type) or cleaned and reconditioned (permanent type) at a frequency that is dictated by conditions. It is better to replace or recondition filters too often than not often enough.
- (c) Totally enclosed air-to-air cooled and totally enclosed fan cooled motors require special cleaning considerations. The external fan must be cleaned thoroughly since any dirt build-up not removed can lead to unbalance and vibration. All of the tubes of the air-to-air heat exchanger should be cleaned using a suitable tube brush having synthetic fiber bristles (not wire of any type).

5.5 Maintenance of anti-friction bearing

5.5.1 Frequency of relubrication

The life of grease varies greatly as a result of types of model, revolution speed, temperature, operational conditions etc. It is, therefore, impossible to be precise about replenishment intervals. However, for normal direct coupling transmission, the periods shown as Table 1 may be used as a guide.

Remarks :

- (a) The periods shown in Table 1 should be halved where bearings are used for belt drive and/or in dirty, or high ambient temperature or high humidity environments.
- (b) Please refer to the lubrication nameplate, if attached to the motor.
- (c) For bearing numbers outside the range of Table 1, please contact TECO.
- (d) If the periods referred to Table 1 for drive-end bearing and opposite drive-end bearing are different, for the convenience of maintenance operation, please take the shorter one the required grease replenishment period of these bearings.

TABLE 1

Bearing number		600 RPM	720 RPM	750 RPM	900 RPM	1000 RPM	1200 RPM	1500 RPM	1800 RPM	3000 RPM	3600 RPM
62XX 63XX 72XX 73XX	6210	-----									
	12	-----								2000Hrs	
	13	-----									
	14	-----								1000Hrs	
	15	-----									
	16	-----								720 Hrs	
	17	-----								2000Hrs	
	18	-----								3000Hrs	
	20	-----									
	22	-----									
	24	-----								1500Hrs	
	26	-----									
	28	-----								2000Hrs	
	30	-----								1000Hrs	
	32	-----								500 Hrs	
	34	-----								1500Hrs	
36	-----										
38	-----								2000Hrs		
		-----								1000Hrs	

Bearing number		600 RPM	720 RPM	750 RPM	900 RPM	1000 RPM	1200 RPM	1500 RPM	1800 RPM		
NU2XX NU3XX	NU214	-----									
	15	-----								2000Hrs	
	16	-----									
	17	-----									
	18	-----								3000Hrs	
	20	-----								1500Hrs	
	22	-----								1000Hrs	
	24	-----									
	26	-----								2000Hrs	
	28	-----								500 Hrs	
	30	-----									
	32	-----									
	34	-----								2000Hrs	
	36	-----								1000Hrs	
	38	-----								2000Hrs	
	40	-----									
44	-----								1000Hrs		
48	-----								1000Hrs		

Bearing number		600 RPM	720 RPM	750 RPM	900 RPM	1000 RPM	1200 RPM	1500 RPM	1800 RPM		
222XX 223XX	22220	-----								300Hrs	
	22	-----									
	24	-----								1000Hrs	
	26	-----								500 Hrs	
	28	-----									
	30	-----								300 Hrs	
	32	-----								500 Hrs	
	34	-----									
	36	-----									
	38	-----								500 Hrs	
	40	-----								300 Hrs	
44	-----										
48	-----								300 Hrs		

5.5.2 Kinds of grease

SHELL Alvania RL3 grease is standard for TECO motors except some special models for which special grease will be shown on the lubrication nameplate. Please use identical grease or its equivalents when maintaining.

ATTENTION !

Do not mix different kinds of grease.

Mixing grease with different type of thickeners may destroy its composition and physical properties. Even if the thickeners are of the same type, possible differences in the additive may cause detrimental effects.

5.5.3 Grease quantity

The amount of grease per replenishment depends on the type, size and construction of the bearings. The maximum amount of one replenishment for each bearing is shown in Table 2.

TABLE 2

Bearing No.		Amount of replenishment	Bearing No.		Amount of replenishment
62XX	6210	30g	63XX	6310	40g
72XX	6212	40	73XX	6312	60
NU2XX	6213	50	NU3XX	6313	80
222XX	6214	50	223XX	6314	80
	6215	60		6315	100
	6216	60		6316	100
	6217	80		6317	120
	6218	80		6318	120
	6220	100		6320	160
	6222	120		6322	220
	6224	120		6324	270
	6226	140		6326	300
	6228	160		6328	400
	6230	180		6330	450
	6232	200		6332	500
	6234	250		6334	600
	6236	300		6336	700
	6238	350		6338	800
	6240	400		6340	900
	6244	450		6344	900
	6248	500		6348	900

* Fill new grease until it overflows and the old grease is entirely replaced.

5.5.4 Re-greasing



If relubrication is to be performed when the motor is running, stay clear of rotating parts.

It is advisable to re-grease when the motor is running to allow the new grease to be evenly distributed inside the bearing.

Before re-greasing, the inlet fitting should be thoroughly cleaned to prevent any accumulated dirt from being carried into the bearing with the new grease. The outlet of grease drainage should be opened to allow the proper venting of old grease.

Use a grease gun to pump grease through grease nipple into bearings. After re-greasing, operate the motor for 10-30 minutes to allow any excess grease to vent out.

5.5.5 Oil relubrication (For oil lubrication types only)

Maintain proper lubrication by checking the oil level periodically and adding oil when necessary. Because of the initial clearing action of the bearing and the expansion of the oil as it comes up operating temperature, the oil level will be higher after the motor has been in operation for a while than it is with the motor at standstill.

Overfilling should be avoided not only because of the possibility that expansion may force the oil over the oil sleeve and on to the rotor, but also because too high an operating oil level prevents the bearing from clearing itself of excess oil. The resultant churning can cause extra loss, high temperatures, and oxidized oil. If, during operation, the oil level goes above the maximum shown on the sight gauge, drain enough oil to bring the level back within the recommended operating range.

Do not permit the operating level to fall below the minimum shown on the gauge.

ATTENTION !

Should it ever become necessary to add excessive amount of make-up oil, investigate immediately for oil leaks.

Change the oil at regular intervals. The time between oil changes depends upon the severity of operating conditions and, hence, must be determined by the motor user. Two or three changes a year is typical, but special conditions, such as high ambient temperature, may require more frequent changes. Avoid operating the motor with oxidized oil.

Use only good grade, oxidation-corrosion-inhibited turbine oils produced by reputable oil companies. The viscosity of the oil to be used depends upon the type and size of the bearing, its load and speed, the ambient temperature, and the amount and temperature of the cooling water (if used). The lubrication nameplate or instructions with each motor specifies the viscosity range of oil suitable for average conditions. The usual oil viscosity recommendations are summarized in Table 3 and Table 4. Operation in ambient temperatures that are near or below freezing may require preheating the oil or the use of special oil. Whenever the motor is disassembled for general cleaning and reconditioning, the bearing housing may be washed out with a suitable cleaning solvent. Be sure that the oil metering hole is clear, and then dry the housing thoroughly before reassembly, and ensure all traces of cleaning solvent have been removed.

Table 3 oil viscosity for vertical motors**

Bearing Type	Oil viscosity	Range of pole
Angular contact ball (72XX , 73XX)	ISO VG32 (150 SSU/100°F)	2 pole
	ISO VG68 (300 SSU/100°F)	4 pole and above
Spherical roller (293XX , 294XX)	ISO VG68 (300 SSU/100°F)	4 pole
	ISO VG150 (700 SSU/100°F)	6 pole and above
RENK Vertical Bearing Inserts Type EV or Kingsbury Type	ISO VG68 (300 SSU/100°F)	4 pole and above

Table 4 oil viscosity for horizontal motors**

Bearing Type	Oil viscosity	Range of pole
Sleeve bearing	ISO VG32 (150 SSU/100°F)	2 pole
	ISO VG46 (200 SSU/100°F)	4 pole
	ISO VG68 (300 SSU/100°F)	6 pole and above

**Remark: When a lubrication nameplate attached to the motor, use lubrication oil it stipulates.

5.5.6 Cleaning and installation of bearings

(a) Apply the proper amount of grease to disassembled parts of the bearing after they have been thoroughly cleaned with high quality cleaning oil. Then protect them from contamination before and during assembly.

(b) Bearing installation

ATTENTION !

Before installing the bearings, make sure that the shaft mounted parts inside the bearings are in place before installation.

Since the bearing is a high precision component, it is important to avoid ingress of dust and foreign matter, and hammering during cleaning and installation. Use extreme care and ensure clean conditions during installation and assembly.

ATTENTION !

The best way for bearing installation is heat shrinking. Knocking and hammering during installation should be avoided absolutely.

The bearing should be heated in a bath of clean oil at temperature of approx. 80°C. After warming, slide the bearings in place quickly and nimbly so that it has not shrunk before being fully in position.

Grease the bearing after the temperature returns to normal, and then reassemble the motor.

5.6 Maintenance of sleeve bearing

5.6.1 Daily inspections

- (a) Ensure the volume and quality of lubricating oil are in compliance with specifications.

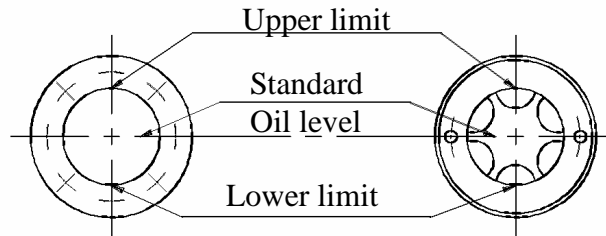

Fig. 16

- (b) Ensure there is motion of the oil ring and it is not clamped.
- (c) The indicator of the shaft endplay should be restricted within the specified range of the red groove of the shaft or the $\pm 3\text{mm}$ range of the drive-end shaft shoulder, or the bearing may be damaged.

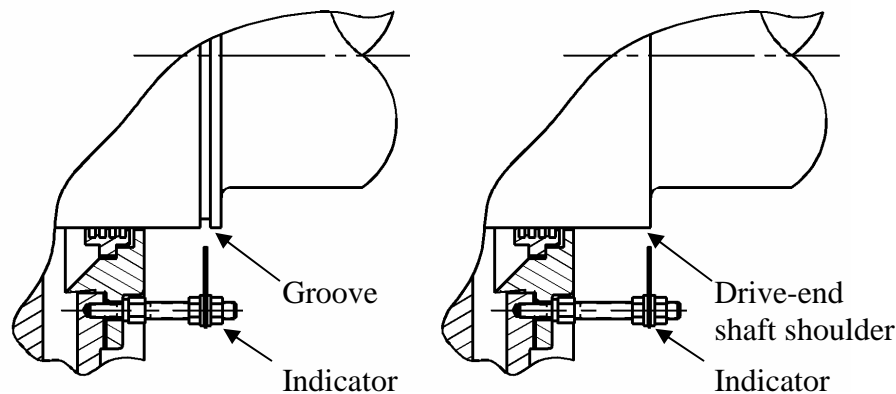

Fig. 17

5.6.2 Regular examination

- (a) Periodical change of oil

The oil reservoirs of self (not flood) lubricated bearings should be drained and refilled about every six (6) months. More frequent changes may be needed on high-speed (3600-rpm) motors or if severe oil discoloration or contamination occurs. In conditions where contamination does occur, it may be advisable to flush the reservoir with kerosene to remove any sediment before new oil is added. Proper care must be taken to thoroughly drain the reservoir of the flushing material before refilling with the new oil.

Refill the reservoir to the center of oil sight glass with a rust and oxidation inhibited turbine grade oil. Refer to the outline and lubrication nameplate for the correct viscosity.

- (b) Quantity of lubrication oil

Please refer to the lubrication nameplate for oil quantity.

(c) Oil viscosity

ISO	Equivalents		Viscosity	
	ESSO	MOBIL	cSt , 40°C	SUS/100°F
VG32	ESSO TERESSO 32	MOBIL DTE OIL LIGHT	32	150
VG46	ESSO TERESSO 46	MOBIL DTE OIL MEDIUM	46	200
VG68	ESSO TERESSO 68	MOBIL OIL HEAVY MEDIUM	68	300
VG150	ESSO NUTO 150	MOBIL DTE OIL EXTRA HEAVY	150	700

5.6.3 Disassembly



Prior to disassembling, ensure the power supplies are disconnected and there are no moving parts.

The bearing sleeve is of the spherically seated, self-aligning type. The opposite drive end bearing is normally insulated for larger motors (or when specified). On some motors, the insulation is bonded to the spherical seat of the bearing housing.

ATTENTION !

Extreme care must be exercised in removing the bearing sleeve from the insulated support to avoid damaging this insulation.

The following is the recommended procedure for removing the bearing sleeve:

- (a) Remove the oil drain plug in the housing bottom and drain the oil sump.
- (b) Remove all instrumentation sensors that are in contact with the bearing sleeve. These would include resistance temperature detectors, thermocouples, thermometers, etc.
- (c) Remove the socket head bolts holding the bearing cap and the inner air seal. The end cover plate must also be removed if the non-drive end bearing is being disassembled. Remove the bearing cap and top half of the inner air seal. Place them on a clean, dry surface to avoid damage to the parting surfaces.
- (d) Remove the top half of the bearing sleeve using suitable eyebolts in the tapped holes provided. Lift the bearing top straight up and avoid any contact with the shoulders of the shaft journals that might damage the thrust faces of the bearing. Place on a clean, dry surface taking care to prevent damage to either the parting surfaces or the locating pins that are captive in the top bearing half.
- (e) Remove the screws at the partings in the oil ring and dismantle the ring by gently tapping the dowel pin ends with a soft face mallet. Remove the ring halves and immediately reassemble them to avoid any mix up in parts or damage to the surface at the partings.
- (f) Pulls up on the garter spring surrounding the floating labyrinth seal and carefully slip out the top half. Rotate the garter spring until the lock is visible. Twist counter-clockwise to disengage the lock, remove the garter spring, and then rotate the lower half of the seal out of the groove in the bearing housing. Note the condition of these floating labyrinth seals. If they are cracked or chipped, they must be replaced. Do not attempt to reuse a damaged seal.
- (g) To remove the bottom bearing half, the shaft must be raised a slight amount to relieve

pressure on the bearing. On the drive end, this can be done by jacking or lifting on the shaft extension. Protect the shaft. On the non-drive end, jacking or lifting can be done using bolts threaded into the tapped holes provided in the shaft end.

- (h) Roll the bottom bearing half to the top of the shaft journal and then lift it using suitable eyebolts threaded into the holes provided. Again avoid any contact with the shaft shoulders that could damage the bearing thrust faces. Place the lower bearing half on a clean, dry surface to protect the parting surfaces.



Use extreme care when rolling out the lower bearing half. Keep the hands and fingers well clear of any position where they might be caught by the bearing half if it were accidentally released and rotated back to its bottom position. Serious personal injury could result.

- (i) Protect the shaft journal by wrapping it with clean, heavy paper or cardboard.

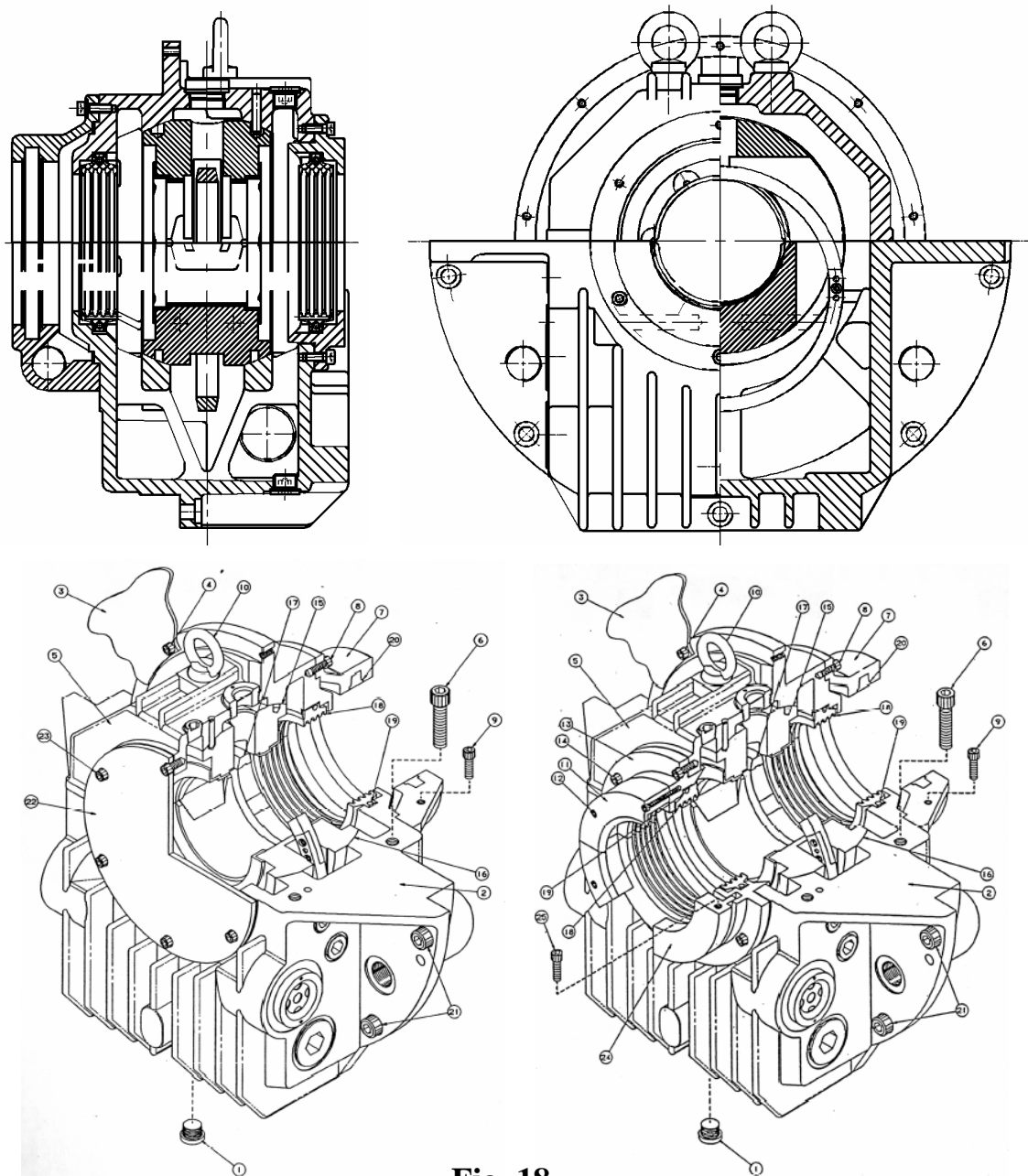

Fig. 18

5.6.4 Reassembly

Bearing reassembly is basically a reverse of the disassembly procedures outlined above, with the following suggestion:

- (a) The interior of the bearing housing should be cleaned and then flushed with clean oil or kerosene.
- (b) The bearing halves and the shaft journal should be wiped clean using lint-free cloth soaked with clean oil.
- (c) All parts should be carefully inspected for nicks, scratches, etc., in any contact surfaces. Such imperfections should be removed by an appropriate method such as stoning, scraping, filing, etc., followed by thorough cleaning.
- (d) Before installing the floating labyrinth seal halves, observe their condition. Do not attempt to use a cracked or chipped seal. The bottom half seal has a set of drilled holes in its side face. These must be placed at the bottom toward the inside of the bearing so that accumulating oil may drain back into the housing.
- (e) Put a bead of Curil-T around the seal half O.D.'s on both sides adjacent to the garter spring groove. This will prevent oil by-passing the seal around its outside.
- (f) Place the bottom seal half on top of the shaft and roll it into position. Install the top half and insert the garter spring pulling up on both ends to permit engaging the lock. Run a bead of Curil-T around the O.D.'s on both sides adjacent to the garter spring groove on this half also.
- (g) Carefully reassemble the two oil ring halves. Inspect the dowel pins for burrs and straightness and make any corrections required. Do not force the ring halves together. Excessive force may alter the roundness or flatness of the oil ring which can change its oil delivery performance.
- (h) Some of the pipe plugs in the housing are metric thread type. These are identified as those which have a copper, lead, or similar material washer. If these plugs are removed, be careful not to lose the washers. Before reassembly, inspect the washers and replace them as required.
- (i) Before installing the bearing cap, observe the position of the floating labyrinth seal. The "tab" must be on top to engage the pocket. Failure to position the seal properly will result in damage when the cap is assembled.

ATTENTION !

- (1) Curil-T is the only approved compound for use in the assembly of the bearings on this motor. Other products may harden and impede the operation.**
- (2) During the reassembly of the bearing parts, a thin layer of Curil-T should be applied to all gaskets and machined interface surface. This suggestion does not apply to the machined surfaces of the bearing liner halves.**
- (3) When seating the bearing shell, apply a thin layer of lube oil at the spherical surface of the liner. Slowly roll the lower bearing liner into the bearing housing making sure that splitted surface of the liner and the housing are flush. Gradually lower the shaft onto the bearing. The weight of the shaft will help rotate the bearing liner so that the babbitt surface of the liner will match the slope of the journal. Sometimes it is required to use a rubber mallet to tap lightly on the bearing housing while slowly rolling the shaft to help this seating operation.**

5.7 Maintenance of slip ring (For Wound Rotor only)



Ensure motor is disconnected from power supplies and there are no accessible moving parts before maintenance operation.

5.7.1 Adjustment of carbon brush

(a) Brush pressure for normal operation :

- Electro-graphite brush... $200 \text{ g/cm}^2 \pm 10\%$

When frequent vibrations are evident or the brush is small (area below 0.5 cm^2), the pressure should be greater than as shown.

(b) Adjustment of brush pressure :

The brush pressure should be adjusted to keep normal operation as it wears.

- The brush pressure may be reduced after use, so it is necessary to re-adjust. For adjustment, please turn adjusting screw, pressure adjusting pin or pressure adjusting plate as shown in Fig.19 to obtain the correct tension ($=0.23 \times \text{brush cross sectional area in cm}^2$) $\pm 10\%$ kg.

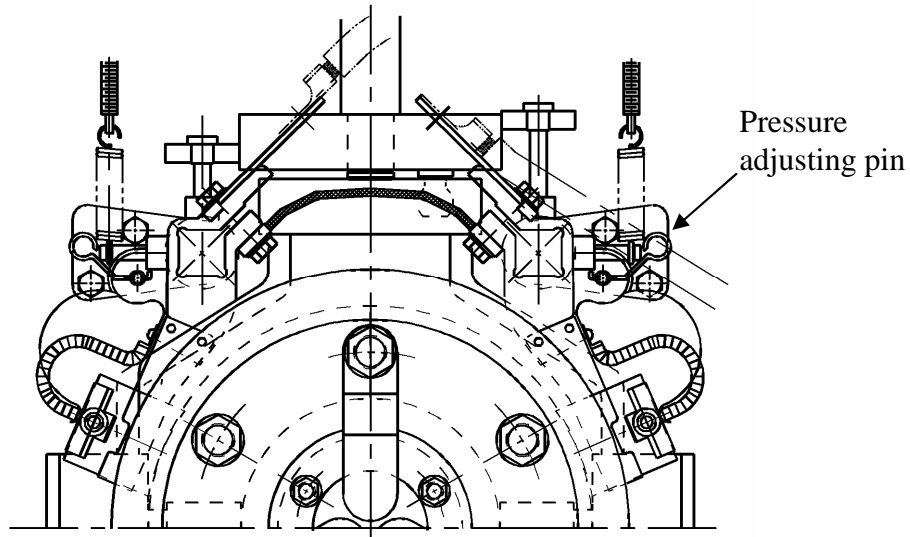

Fig. 19

(c) Brush pressure need not be adjusted if constant force spring is used as shown in Fig.20 and Fig. 21.

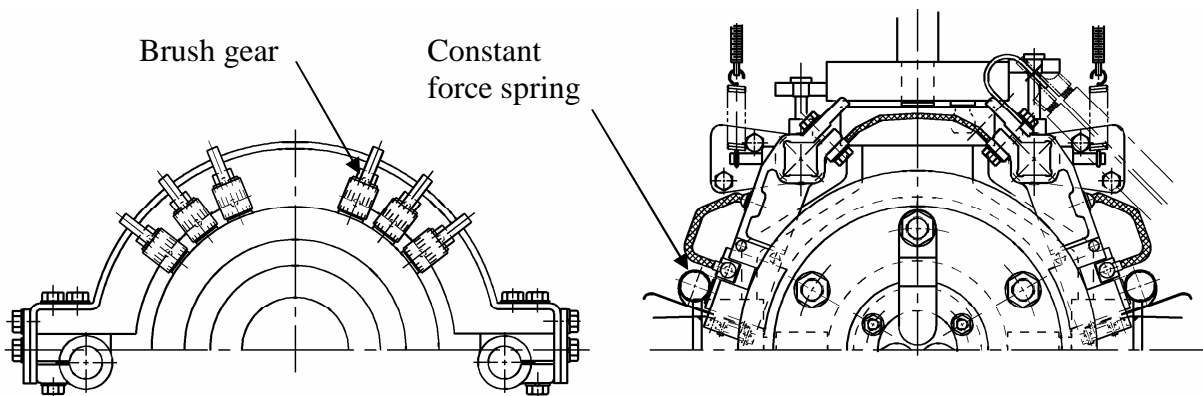

Fig. 20

Fig. 21

5.7.2 Brush replacement

The carbon brush is a part of the equipment which easily worn away, replace it after it is worn to 1/2~3/5 of original size.

(a) Brush material

The brush material is important to the performance of the motor. Only the most appropriate materials are chosen by TECO, and are listed on the nameplate of motor. It is important to know this when you replace the brush, so a recommended type is used.

(b) Dimensions

Brush, holder and gap between them, please refer to CNS 2322 C4051 or JIS C2802.

ATTENTION !

The gap between a brush and its holder is important for good performance and safety of the motor.

(c) Adjustment of new brushes (Shown in Fig.22)

- (1) Polish the new brush with a file until it assumes the appropriate contour of the slip ring which it touches.
- (2) Place sandpaper (JIS R6252 NO.40.....50) on the slip ring with the abrasive face of the paper against the brush to induce a closer contact by rubbing against each other.
- (3) Repeat item 2 with fine sand-paper (JIS R6252 NO. 100 to 200) until the contact surface between brush and slip ring exceeds 80%.
- (4) Finally, clean the contaminated slip ring and brush with clean cloth or compressed air.

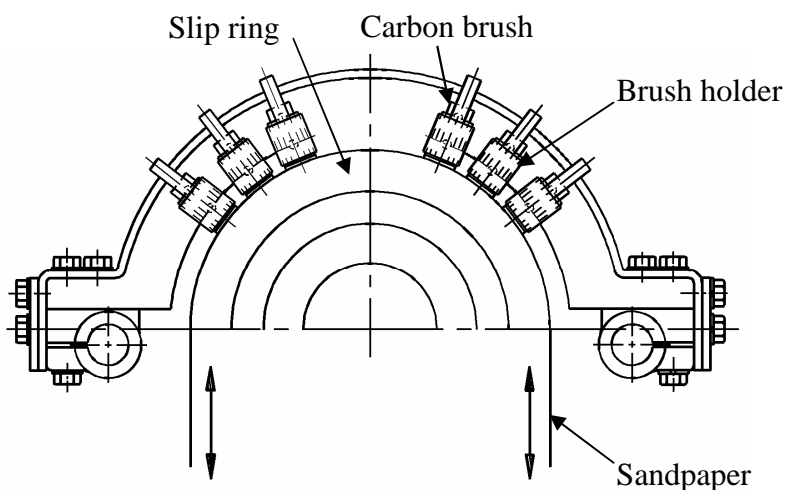

Fig. 22

5.8 Maintenance of non-reverse ratchet mechanism (For Vertical high Thrust Motor only)

5.8.1 Non-reverse ratchet mechanism

In the pump piping system, a check valve and a stop valve should be installed in the discharge line. The check valve, placed between the pump and the stop valve, is to protect the pump from reverse flow and excessive back pressure. The stop valve is used in priming, starting and when shutting down the pump. It is advisable to close the stop valve before stopping the pump. This is especially important when the pump is operated against a high static head.

TECO vertical high thrust motors are equipped with non-reverse ratchet (N.R.R.) mechanism only when requested by the pump manufacturer. Typical construction of N.R.R. mechanism is shown as Fig.23 below.

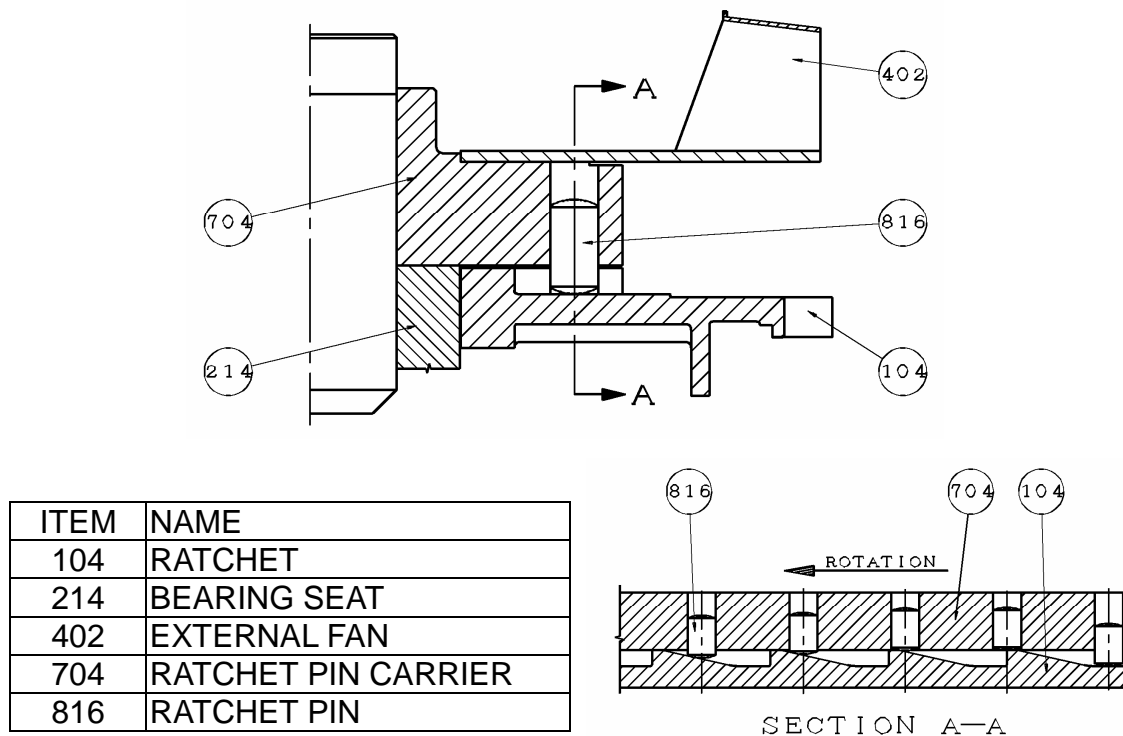

Fig. 23

The N.R.R. mechanism keeps the pump and motor from rotating in the reverse direction. Thus prevents damage from over speeding and damage to water-lubricated pump shaft bearings when, on shutdown, the falling water column tends to drive the pump in the reverse direction.

In normal operation, the ratchet pins are lifted by the ratchet teeth and are held clear by centrifugal force and friction as the motor comes up to speed. When power is removed, the speed decreases and the pins fall. At the instant of reversal, a pin will catch in a ratchet tooth and prevent backward rotation.

5.8.2 Service life

The service life of ratchet pins depends not only on the reverse shock load between the pin and ratchet tooth when pump stopped but also the frequency of pump starting and stop in application.

Provided that the pins are deformed due to thus reverse shock load, then the up and down motion of ratchet pins could be sluggish or jammed and that unusual noises shall arise.

The recommended replacement period for these ratchet pins is every three (3) years. If the reverse shock load is greater than 30% of motor rated torque or the starting frequency is more than twice per day, then the replacement period is to be halved.

ATTENTION !

The check valve and stop valve in the discharge line should be regularly inspected and maintained to assure the normal function of these valves. This is important to protect the pump and motor from damage and increase the service life of N.R.R. mechanism.

6. FAULT FINDING AND RECOGNITION

Kinds of Breakdown	Symptoms	Possible causes	Remedies
Fail to start without load	Motionless and soundless	Power-off	Consult power company
		Switch-off	Switch-on
		No fuse	Install fuse
		Broken wiring	Check wiring and repair
		Broken lead	Check wiring and repair
		Broken windings	Check windings and repair
	Fuse blowing. (Automatic switch trips off, slow start with electromagnetic noise)	Short circuit of circuit switches	Check circuit switches and replace
		Incorrect wiring	Check wiring according to nameplate
		Poor contact at terminals	Lock tightly
		Windings grounded	Factory repair
		Broken windings	Factory repair
		Poor contact of circuit switches	Check and repair
		Broken wiring	Check and repair
		Poor contact of starting switches	Check and repair
Loading after start	Fuse blowing. Fail to restart due to trip-off of automatic switch	Insufficient capacity of fuse	Replace fuse if wiring permits
		Overload	Lighten load
		High load at low voltage	Check circuit capacity and reduce load
	Overheating motor	Overload or intermittent overload	Lighten load
		Under-voltage	Check circuit capacity and power source
		Over-voltage	Check power source
		Ventilation duct clogged	Remove the foreign matter in the duct
		Ambient temperature exceeds 40°C	Correct insulation class to B or F, or lower ambient temperature.
		Friction between rotor and stator	Factory repair
		Fuse blown (Single-phase rotating)	Install the specified fuse
Poor contact of circuit switches	Check and repair		
Poor contact of circuit starting switches	Check and repair		
Unbalanced three-phase voltage	Check circuit or consult power company		

Kinds of Breakdown	Symptoms	Possible causes	Remedies	
Loading after start	Speed falls sharply	Voltage drop	Check circuit and power source	
		Sudden overload	Check machine	
		Single-phase rotating	Check circuit and repair	
	Switch overheat	Insufficient capacity of switch	Replace switch	
		High load	Lighten load	
	Bearing overheating	High belt tension	Adjust belt tension	
		Slack belt tension	Adjust belt tension	
		Misalignment between motor and machine shafts	Re-align	
		Over speed of bearing outer-ring	Adjust bracket	
		High bearing noise	Replace the damaged bearing	
Noise	Electromagnetic noise induced by electricity	Occurrence from its first operation	May be normal	
		Sudden sharp noise and smoking	Short circuit of windings Should be repaired at factory	
	Bearing noise	Noise of low shishi or Thru-Thru	May be normal	
		Kala-Kala as result of poor lubrication	Grease	
		Kulo-Kulo as a result of deteriorated grease	Clean bearing and grease	
		Sa-Sa or larger noise	Replace the damaged bearing	
	Mechanical noise caused by machinery	Loose belt sheave	Adjust key and lock the screw	
		Loose coupling or skip	Adjust the position of couplings, lock key and screw	
		Loose screw on fan cover	Lock fan cover screw tightly	
		Fan rubbing	Adjust fan position	
		Rubbing as a result of ingress of foreign matters	Clean motor interior and ventilation ducts	
		Wind noise	Noise induced by air flowing through ventilation ducts	
		Induced by conveyance machine	Repair machine	
	Vibration	Electromagnetic vibration	Short circuit of windings	Factory repair
			Open circuit of rotor	Factory repair
Mechanical vibration		Unbalanced rotor	Factory repair	
		Unbalanced fan	Factory repair	
		Broken fan blade	Replace fan	
		Unsymmetrical centers between belt sheaves	Align central points	
		Central points of couplings do not lie on the same level	Adjust the central points of couplings to the same level	
		Improper mounting installation	Lock the mounting screws	
		Motor mounting bed is not strong enough	Reinforce mounting bed	
		Mounting bed vibration caused by near machines	Eliminate the vibration source near motor	

Remarks:

- (1) Circuit switches: These include knife switches, electromagnetic switches, fuse and other connection switch etc.
- (2) Starting switches: These include Delta-Star starters, compensate starters, reactance starters, resistor starters, starting controllers etc.

7. TECO Worldwide Operations

HEAD OFFICE

Teco Electric & Machinery Co. Ltd
10F. No. 3-1 Yuan Cyu St.
Nan-Kong, Taipei 115
Taiwan R.O.C.
Tel: +886 2 6615 9111
Fax: +886 2 6615 2253
www.tecomotor.com.tw

UNITED STATES

Teco-Westinghouse Motor Company
PO Box 227 (78680-0277), 5100 N.IH35
Round Rock Texas 78681 USA
Tel: +1 512 255 4141
+1 800 873 8326
www.tecowestinghouse.com

CANADA

Teco-Westinghouse Motors Inc. (Canada)
18060-109th Ave
Edmonton, Alberta T5S 2K2 Canada
Tel: +1 780 444 8933
Fax: (780) 486-4575
24 HR Emergency Pager: (780) 419-7734
Toll Free: 800-661-4023
Fax Toll Free: 888-USE-TWMI
www.twmi.com

NETHERLANDS

Teco Electvic & Machinery B.V.
Teco's European Head Office
Rivium 3e Straat 27
2909 LH Capelle a/d IJssel
The Netherlands
Tel: +31 10 266 6633
Fax: +31 10 202 6415

UNITED KINGDOM

Teco Electric Europe Limited
26 Bond, Europa Way Old Trafford,
Manchester M17 1WF England
Tel: +44 161 877 8025
www.teco.co.uk

GERMANY

Teco Electvic & Machinery B.V.
Niederlassung Deutschland
Marktstrasse 69
37441 Bad Sachsa Germany
Tel: +49 5523 95340
Fax: +49 5523 953424
www.teco-westinghouse.de

SPAIN

Teco Electric & Machinery B.V.
Spain Office
C/Sancho Dávila 8 4ºF
28028 Madrid Spain
Tel: +34 91 725 1718
Fax: +34 91 355 6963

SOUTH AFRICA

ArmCoil Afrika (Pty) Ltd.
Unit 3 Prestige Park 127 Main Reef Road
Technikon Roodepoort
PO Box 500 Maraisburg 1700
Gauteng South Africa
Tel: +2711 763 2351
Fax: +0866 318 588
www.armcoil.co.za

SAUDI ARABIA

Al-Quraishi Electrical Services of Saudi Arabia
P.O.Box 7386-Dammam 31462
Kingdom of Saudi Arabia
Phone : +966-3-835-1155
Fax : +933-3-835-2298
www.agesa.com

JAPAN

Sankyo Co., Ltd.
26th fl. World Trading Center Bldg.
2-4-1 Hamamatsucho Minato-ku
Tokyo Japan 105-6126
Tel: +81 3 3435 9729
Fax: +81 3 3578 8381

AUSTRALIA

Sydney Office
Teco Australia Pty Ltd.
335-337 Woodpark Road
Smithfield NSW 2164 Australia
Tel: +61 2 9765 8118
www.teco.com.au

Melbourne Office
Teco Australia Pty Ltd.
16 Longstaff Road
Bayswater VIC 3153 Australia
Tel: +61 3 9720 4411

Brisbane Office
Teco Australia Pty. Ltd.
50 Murdoch Circuit,
Acacia Ridge QLD 4110 Australia
Tel: +61 7 3373 9600

Perth Office
Teco Australia Pty Ltd.
28 Belgravia Street,
Belmont WA 6104 Australia
Tel : +61 8 9479 4879

NEW ZEALAND

Teco New Zealand Pty Ltd.
Unit 3 477 Great South Road
Penrose Auckland New Zealand
Tel: +64 9 526 8480

CHINA

Suzhou Teco Electric & Machinery Co., Ltd
No. 1 Changjiang W.Rd.South-Dam
Industrial Park Liuhe Zhen, Taicang City,
Suzhou
Jiangsu Province, PRC
Tel: +86 512 5361 9901
Fax: +86 512 5396 1058

Wuxi Teco Electric & Machinery Co., Ltd.
No. 9 South Of Changjiang Road, New Zone,
Wuxi
Jiangsu Province. PRC
Tel: + 86 510 8534 2005
Fax: +86 510 8534 2001
www.wuxiteco.com

Jiangxi Teco Electric & Machinery Co., Ltd.
1328 Jinggangshan Rd., Nanchang
Jiangxi, PRC
Tel:+86 791 641 3690
Fax:+86 791 641 4228

Shanghai Office: Rm 321 Building No.6
Lane 1279 Zhongshan W. Rd.
Shanghai P.R.C
Tel: +86 21 5116 8255
Fax: +86 21 6278 8761

HONG KONG

Tecoson Industrial Development (HK) Co., Ltd.
Rm 3712 Hong Kong Plaza
186-191 Connaught Rd West, Hong Kong
Tel: +852 2858 3220

SINGAPORE

Teco Electric & Machinery (PTE) Ltd.
18 Chin Bee Drive
Singapore 619865
Tel: +65 6 265 4622
www.teco.com.sg

INDONESIA

P.T. Teco Multiguna Elektro
JL Bandengan Utara No. 83/1-3
Jakarta Utara-14400 Indonesia
Tel: +62 21 662 2201

MALAYSIA

STE Marketing SDN BHD
6 Jalan Firma 2 Kawasan Perind. Tebrau 1
81100 Johor Bahru Johor Malaysia
Tel: +60 7 354 8008

THAILAND

Teco Electric & Machinery (Thai) Co. Ltd.
128/1 Soi Watsrivareenoi
Moo 7 Bangna-Trad Road Km 18
Bangchalong Bangplee
Samuthprakarn 10540 Thailand
Tel: +662 3371311- 20

VIETNAM

TECO(Vietnam)Electric & Machinery Co., Ltd.
KCN LONG Thanh, Huyen Long Thanh, Tinh
Dong Nai.
Phone: 84-061-3514108
Fax: 84-061-3514410



TECO Electric & Machinery Co. Ltd

10F. No. 3-1 Yuan Cyu St. Nan-Kong, Taipei 115 Taiwan R.O.C.

TEL : 886-2-66159111

FAX : 886-2-66152253

3A057D872E REV.06